



LIGO 3 Strawman Design, Team Red

B. Barr¹, A. Bell¹, C. Bell¹, C. Bond², D. Brown², F. Brueckner², L. Carbone², K. Craig¹,
A. Cumming¹, S. Danilishin³, K. Dooley⁴, A. Freise², T. Fricke⁴, P. Fulda², S. Giampsis⁵,
N. Gordon¹, H. Grote⁴, G. Hammond¹, J. Harms⁶, S. Hild^{1,*}, J. Hough¹, S. Huttner¹, R. Kumar¹,
H. Lück⁴, N. Lockerbie⁷, J. Macarthur¹, I. Martin¹, P. Murray², S. Reid¹, S. Rowan¹,
D. Shoemaker⁸, B. Sorazu¹, K. Strain¹, S. Tarabrin⁴, K. Tokmakov¹ and N. Voronchev³
+H. Wittel



¹SUPA, School of Physics and Astronomy, The University of Glasgow, Glasgow, G12 8QQ, UK

²University of Birmingham, Birmingham, B15 2TT, UK

³Moscow State University, Moscow, 119992, Russia

⁴Max-Planck-Institut für Gravitationsphysik and Leibniz Universität Hannover, D-30167 Hannover, Germany

⁵University of Wisconsin-Milwaukee, Milwaukee, Wisconsin 53201, USA

⁶California Institute of Technology, Pasadena, California 91125, USA

⁷University of Strathclyde, Glasgow, G1 1XQ, UK

⁸Massachusetts Institute of Technology, Cambridge, Massachusetts 02139, USA



Contents

- ➔ Background / Introduction
- ➔ Description of the Team Red design
- ➔ Discussion of a xylophone option
- ➔ What can we learn from all this?



Introduction

- ➔ With 2nd generation instruments under construction it is now time to look what comes afterwards.
- ➔ In Europe the design study for the third generation **Einstein telescope** (based on an underground xylophone with 10km armlength) has been completed.

<https://tds.ego-gw.it/itf/tds/index.php?callContent=2&callCode=8709>

- ➔ **What are the upgrade options for Advanced LIGO?**

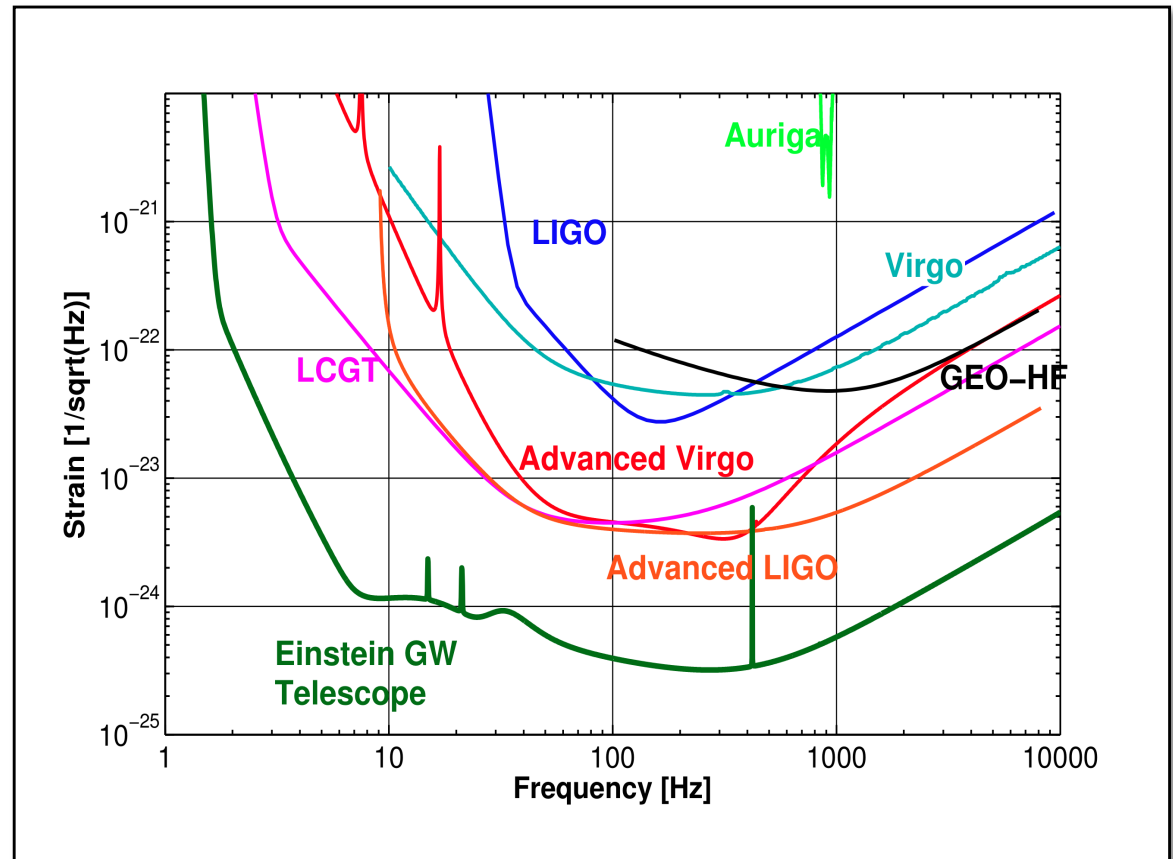



What shall LIGO 3 look like?

One just needs to copy and paste the ET design.

(If that is not the optimal solution then there is something wrong with the ET design.)

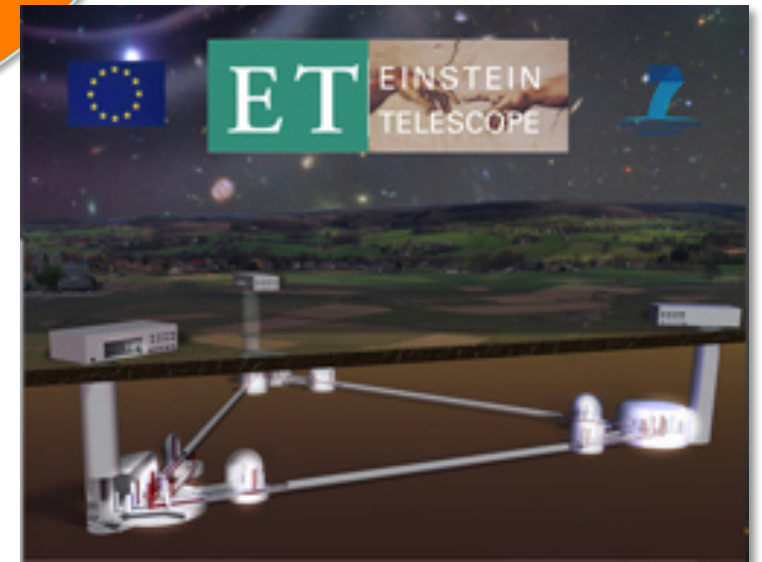



Upgrades within the Advanced LIGO infrastructure

- ➔ However, the advanced LIGO baseline sensitivity is far away from the **infrastructure limits**.
- ➔ Infrastructure limit was usually defined as combination of residual gas noise and gravity gradient noise.
- ➔ **So there is plenty of room for advanced LIGO upgrades within the existing infrastructure! And this will be the focus of the rest of this presentation**

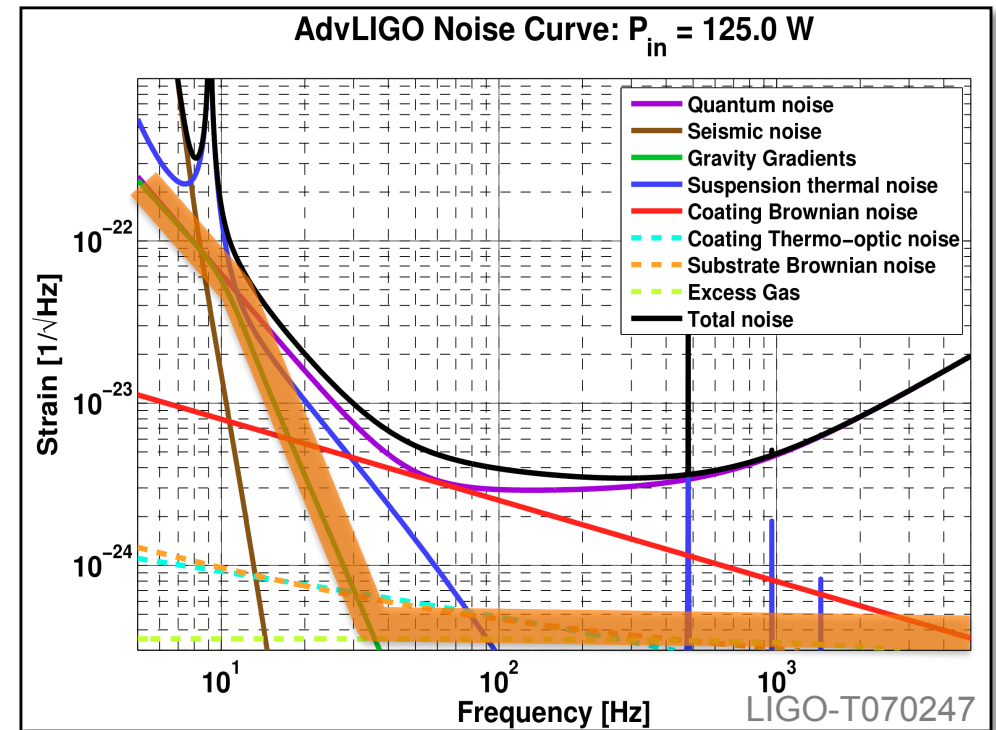



What are the boundaries?

- ➔ At the beginning one needs to set the boundaries:
 - **When** is it going to happen?
 - What is the maximum **budget**?
 - Only include **mature technologies** or shall we include technologies that we are not sure if they work or not?
 - **Technical limitations** (e.g. stick to 1MW or go beyond)?
 - Do we only consider **incremental upgrades**?

- ➔ **Unfortunately, at the moment we simply do not know!**

- ➔ **So we need to throw in our guesses. ALSO it might be useful to have different designs available each fitting a certain future scenario.**



Two different scenarios

In this presentation I would like to show you two very different scenarios:

➔ **Red Team design:**

- Upgraded **room temperature** interferometer
- **Larger beams, heavier test masses, longer suspension, frequency dependent squeezed light, gravity gradient noise subtraction, improved coating noise ...**
- Provides broadband improvement of **a factor 3-4 => 600 Mpc**

➔ **Red Team design xylophone:**

- Build a **2-tone xylophone** detector inside existing vacuum system
- **Cryogenic interferometer** with low power to cover the low-frequency region.

As we will see, these 2 are probably close to the 2 opposite ends of the spectrum of available scenarios.



Contents

- ➔ Background / Introduction
- ➔ Description of the Team Red design
- ➔ Discussion of a xylophone option
- ➔ What can we learn from all this?



Suspension Thermal Noise

Assume a boosted
aLIGO Quad-suspension:

➔ Increased length of last stage to **1.2m** to reduce suspension thermal noise.

➔ Increased **mirror mass of 160kg** to reduce suspension thermal noise (and radiation pressure noise and coating noise)

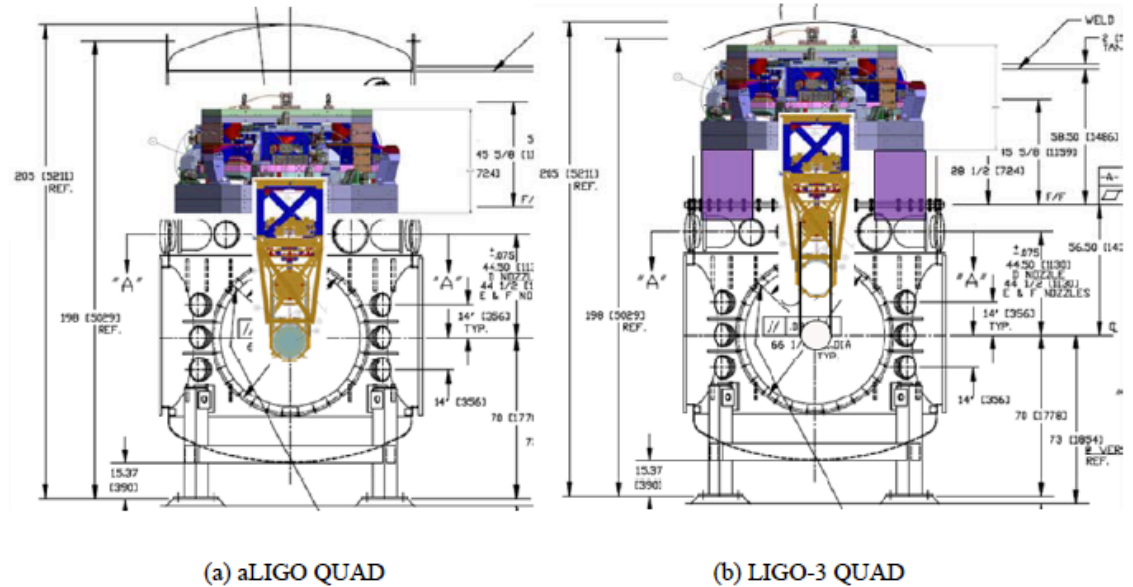

Test Masses and Suspensions		
Mirror Material	Fused Silica	Fused Silica
Main Test Mass Diameter	35 cm	55 cm
Main Test Mass Weight	42 kg	160 kg
Masses in Main Quad (from top)	22 kg/22 kg/40 kg/40 kg	44 kg/66 kg/120 kg/160 kg
Masses in Reaction Chain (from top)	22 kg/22 kg/40 kg/40 kg	22 kg/22 kg/40 kg/40 kg
Total Mass of a Main Suspension	250 kg	520 kg
Length of Final Suspension Stage	0.6 m	1.2 m
Fused Silica Fibre Diameter	400 μm	566 μm
Fibre Diameter at Bending Point	800 μm	1624 μm



Suspension Thermal Noise

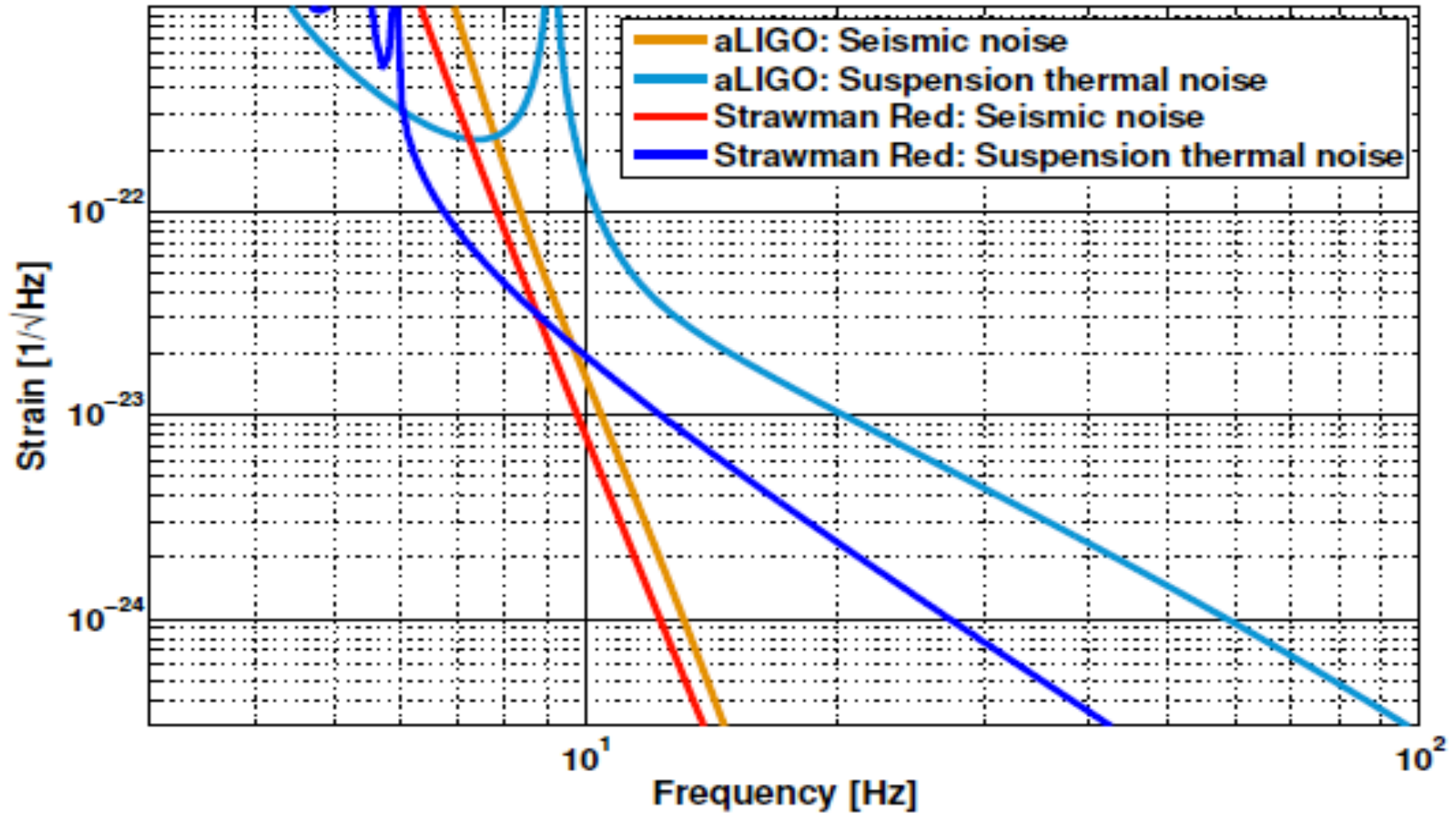



Newtonian Noise

- ➔ Red design assumes a reduction factor of 5.
- ➔ Please note seismic noise is not constant. The factor 5 assumed guarantees that 90% of the time the Newtonian noise would be below the LIGO-3 red sensitivity.

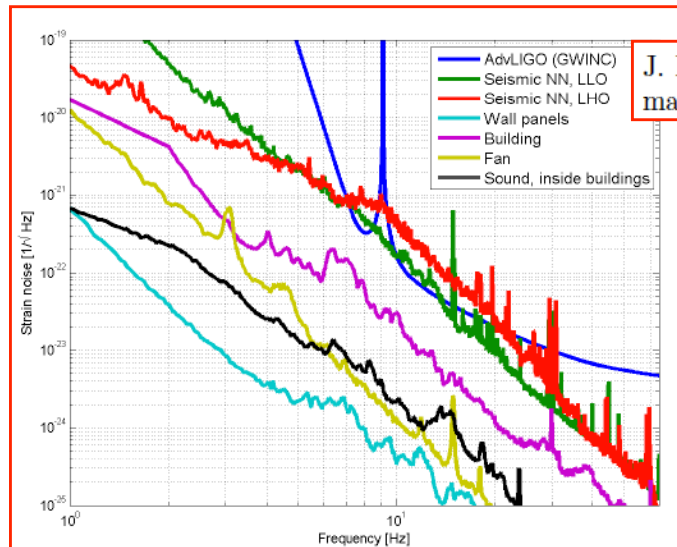

J. Driggers and J. Harms, "Results of phase 1 newtonian noise measurements at the ligo sites, february-march 2011," *LIGO DCC*, vol. T1100237, 2011.

Used seismic data from:

LIGO-T0900312-v1	<i>LIGO</i>	June 26, 2009
Reference Seismic Data for LLO		
P. Fritschel, S Waldman		



Coating Brownian noise

- ➔ Assumed an overall improvement by a factor **3.2**.
- ➔ Factor **1.6** from increased beam sizes.
- ➔ Another factor of **2** on top of this from either:
 - Better coatings
 - Khalili cavities
 - Resonant waveguide mirrors



Quantum noise

- ➔ We kept the interferometer configuration and the mirror reflectivities the same as in aLIGO baseline.
- ➔ **Introduced frequency dependent input squeezing.**
- ➔ Key aspects: **achievable squeezing level** & **required length of filter cavity**

Laser and Optical Parameters		
Laser Wavelength	1064 nm	1064 nm
Optical Power at Test Masses	730 kW	730 kW
Arm Cavity Finesse	450	450
Signal Recycling	$T = 20\%$, tuned	$T = 20\%$, tuned
Squeezing Factor	n.a.	20 dB
Filtercavity (FC) length	n.a.	300 m
FC Detuning	n.a.	-16.8 Hz
FC Input Mirror Transmittance	n.a.	425 ppm
Squeezing Losses	n.a.	9% + 30 ppm roundtrip in FC



Squeezing losses

Frequency independent losses:

- Generation of squeezing: 3%
- Optical isolation: 3 x 0.8%
- Mode matching to IFO and to OMC: 2 x 1%
- OMC loss and QE of PD: 2 x 0.5%
- Mode matching to filter cavity: 1%

= 9% in total

+

Frequency dependent loss (from filtercavity):

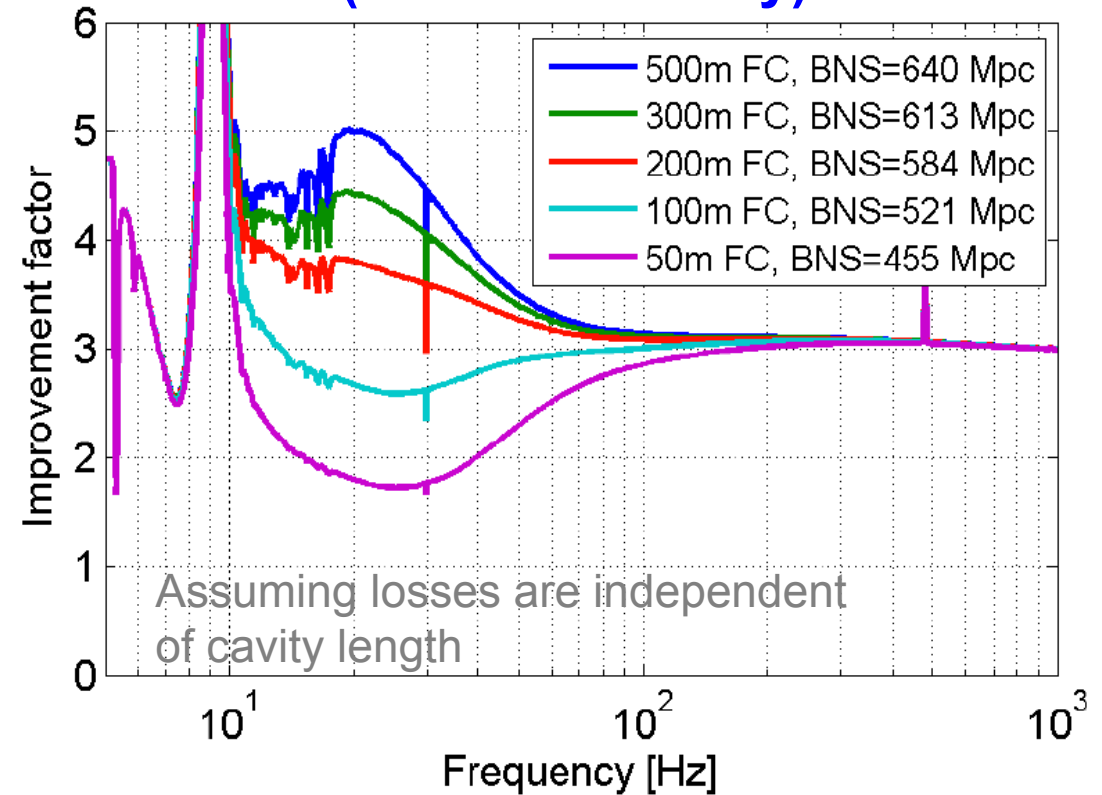

Starting from 20dB squeezing inside the squeezing crystal the losses reduce the observed squeezing to about 9-10dB



Team Red Sensitivity

- ➔ So if we put all the aforementioned things together we get the following sensitivity:
- ➔ Overall an improvement of a factor 3 at all frequencies above 100 Hz. And a factor 3-4 below 100 Hz.
- ➔ The binary neutron star inspiral range would improve from about 200 Mpc to above 600 Mpc.

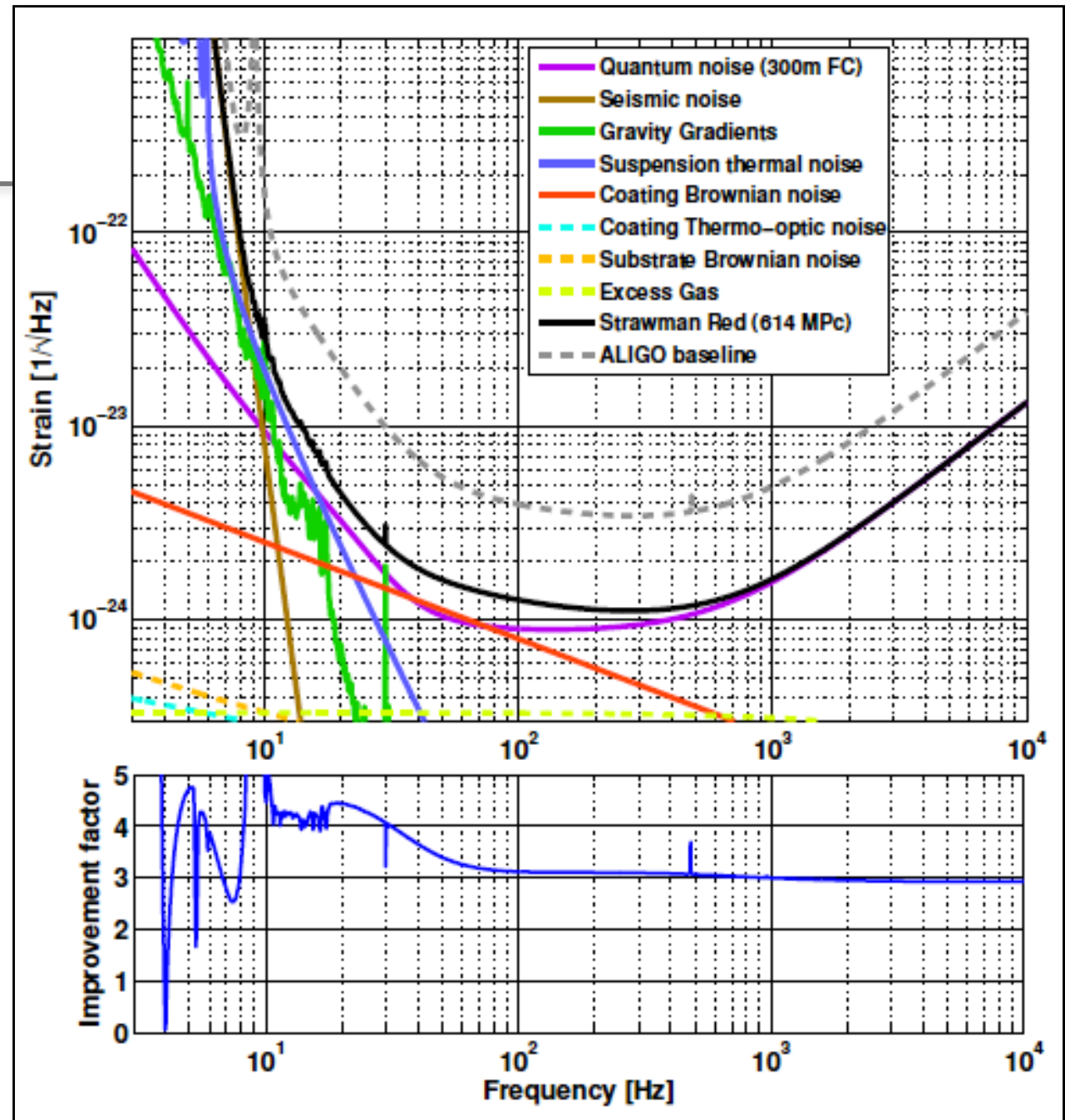



Team Red parameters

- ➔ Rough cost estimate (only hardware included) is about **20 million \$ per interferometer.**
- ➔ Please note: Apart from the 'magic' factor of 2 in coating noise improvement, we have all the know-how required to actually build such an instrument now!

Strawman Red Design Overview		
Subsystem and Parameters	Advanced LIGO Baseline Design	Strawman Red Design
Sensitivity		
Binary Neutron Star Inspiral Range	200 Mpc	614 Mpc
Anticipated Strain Sensitivity	$3.5 \cdot 10^{-24} / \sqrt{\text{Hz}}$ @ 300 Hz	$1.2 \cdot 10^{-24} / \sqrt{\text{Hz}}$ @ 250 Hz
Instrument Topology		
Interferometer	Dual-recycled Michelson with Armcavities	Dual-recycled Michelson with Armcavities
Quantum Noise Reduction	n.a	Frequency-dependent input squeezing
Laser and Optical Parameters		
Laser Wavelength	1064 nm	1064 nm
Optical Power at Test Masses	730 kW	730 kW
Arm Cavity Finesse	450	450
Signal Recycling	$T = 20\%$, tuned	$T = 20\%$, tuned
Squeezing Factor	n.a.	20 dB
Filtercavity (FC) length	n.a.	300 m
FC Detuning	n.a.	-16.8 Hz
FC Input Mirror Transmittance	n.a.	425 ppm
Squeezing Losses	n.a.	9% + 30 ppm roundtrip in FC
Test Masses and Suspensions		
Mirror Material	Fused Silica	Fused Silica
Main Test Mass Diameter	35 cm	55 cm
Main Test Mass Weight	42 kg	160 kg
Masses in Main Quad (from top)	22 kg/22 kg/40 kg/40 kg	44 kg/66 kg/120 kg/160 kg
Masses in Reaction Chain (from top)	22 kg/22 kg/40 kg/40 kg	22 kg/22 kg/40 kg/40 kg
Total Mass of a Main Suspension	250 kg	520 kg
Length of Final Suspension Stage	0.6 m	1.2 m
Fused Silica Fibre Diameter	400 μm	566 μm
Fibre Diameter at Bending Point	800 μm	1624 μm
Coating Noise Reduction		
Improvement Factors	n.a.	factor 1.6 from increased beam size PLUS factor 2 from either (i) better coatings, OR (ii) Khalili cavities, OR (iii) waveguides
Operation Temperature	290 K	290 K
IM/EM ROC	1934/2245 m	1849/2173 m
IM/EM spotsize	5.31/6.21 cm	8.46/9.95 cm
Khalili cavity length	n.a.	50 m
Gravity Gradient Noise		
Assumed Seismic Level	???	LLO ETMX, 90th percentile
Assumed subtraction factor	n.a.	5



More Details of the Team Red Design

- ➔ For details please see documents on the DCC:
- ➔ 50 page long description of the Team Red Design can be found at <https://dcc.ligo.org/cgi-bin/private/DocDB/ShowDocument?docid=78100>
- ➔ The sensitivity data for the Team Red design are available at <https://dcc.ligo.org/cgi-bin/private/DocDB/ShowDocument?docid=86562>

LIGO 3 Strawman Design, Team Red

B. Barr¹, A. Bell¹, C. Bell¹, C. Bond², D. Brown², F. Brueckner², L. Carbone², K. Craig¹, A. Cumming¹, S. Danilishin³, K. Dooley⁴, A. Freise², T. Fricke⁴, P. Fulda², S. Giampis⁵, N. Gordon¹, H. Grote⁴, G. Hammond¹, J. Harms⁶, S. Hild^{1,*}, J. Hough¹, S. Huttner¹, R. Kumar¹, H. Lück⁴, N. Lockerbie⁷, J. Macarthur¹, I. Martin¹, P. Murray², S. Reid¹, S. Rowan¹, D. Shoemaker⁸, B. Sorazu¹, K. Strain¹, S. Tarabrin⁴, K. Tokmakov¹ and N. Voronchev³

Issue: 2

Date: January 25, 2012

¹ SUPA, School of Physics and Astronomy, The University of Glasgow, Glasgow, G12 8QQ, UK

² University of Birmingham, Birmingham, B15 2TT, UK

³ Moscow State University, Moscow, 119992, Russia

⁴ Max-Planck-Institut für Gravitationsphysik und Leibniz Universität Hannover, D-30167 Hannover, Germany

⁵ University of Wisconsin-Milwaukee, Milwaukee, Wisconsin 53201, USA

⁶ California Institute of Technology, Pasadena, California 91125, USA

⁷ University of Strathclyde, Glasgow, G1 1XQ, UK

⁸ Massachusetts Institute of Technology, Cambridge, Massachusetts 02139, USA

*E-Mail: stefan.hild[at]glasgow.ac.uk



How does the red design compare to blue and green?

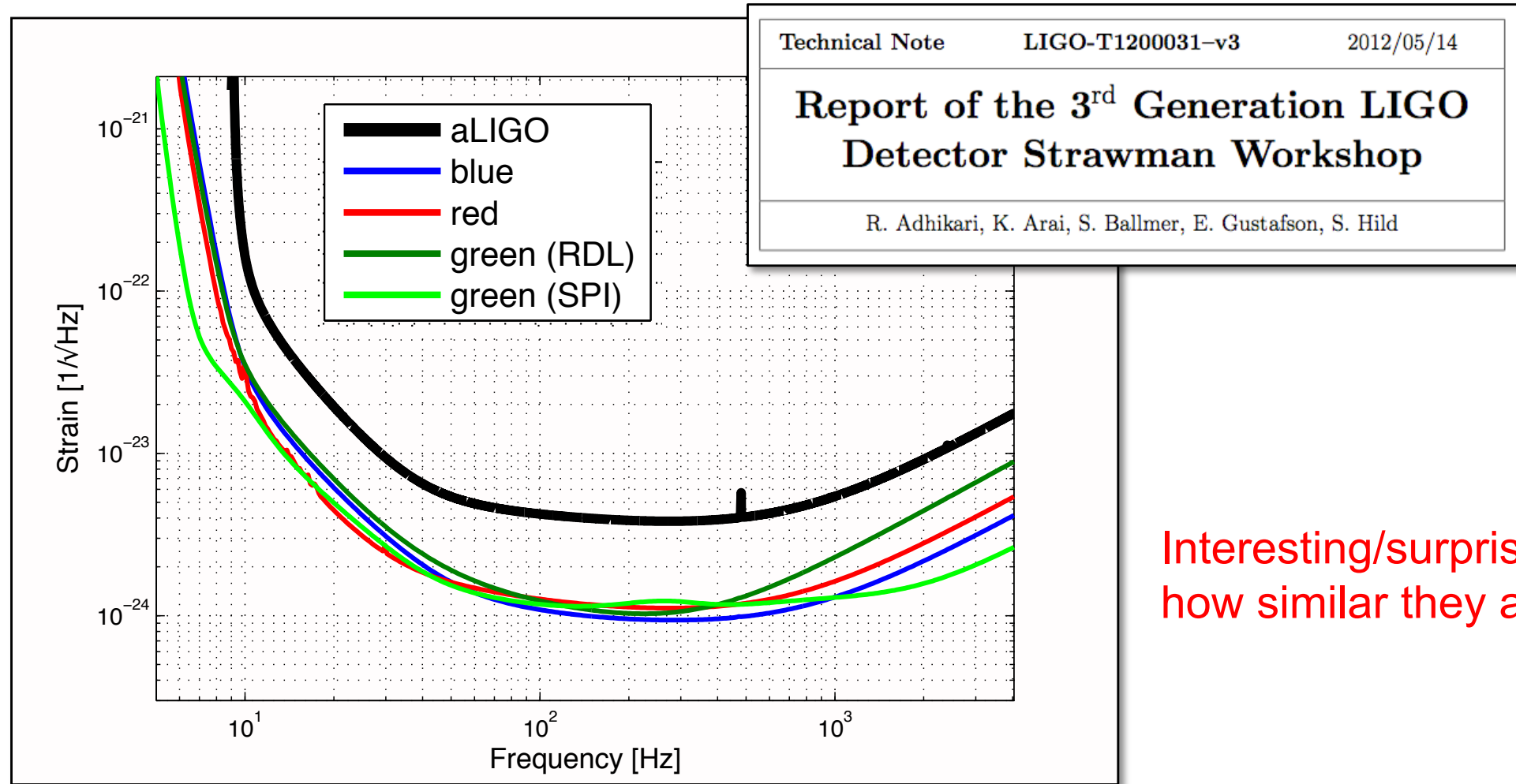

Interesting/surprising how similar they are ...



Contents

- ➔ Background / Introduction
- ➔ Description of the Team Red design
- ➔ Discussion of a xylophone option
- ➔ What can we learn from all this?



Is room temperature really the only way forward?



Come on!!
Where is your vision?

We know that in the long-term cryogenic test masses will be the best for low frequency sensitivity (see Kagra and ET investigations) The earlier we start to learn how to do this the better we will be off later on.



The cooler the better the noise!

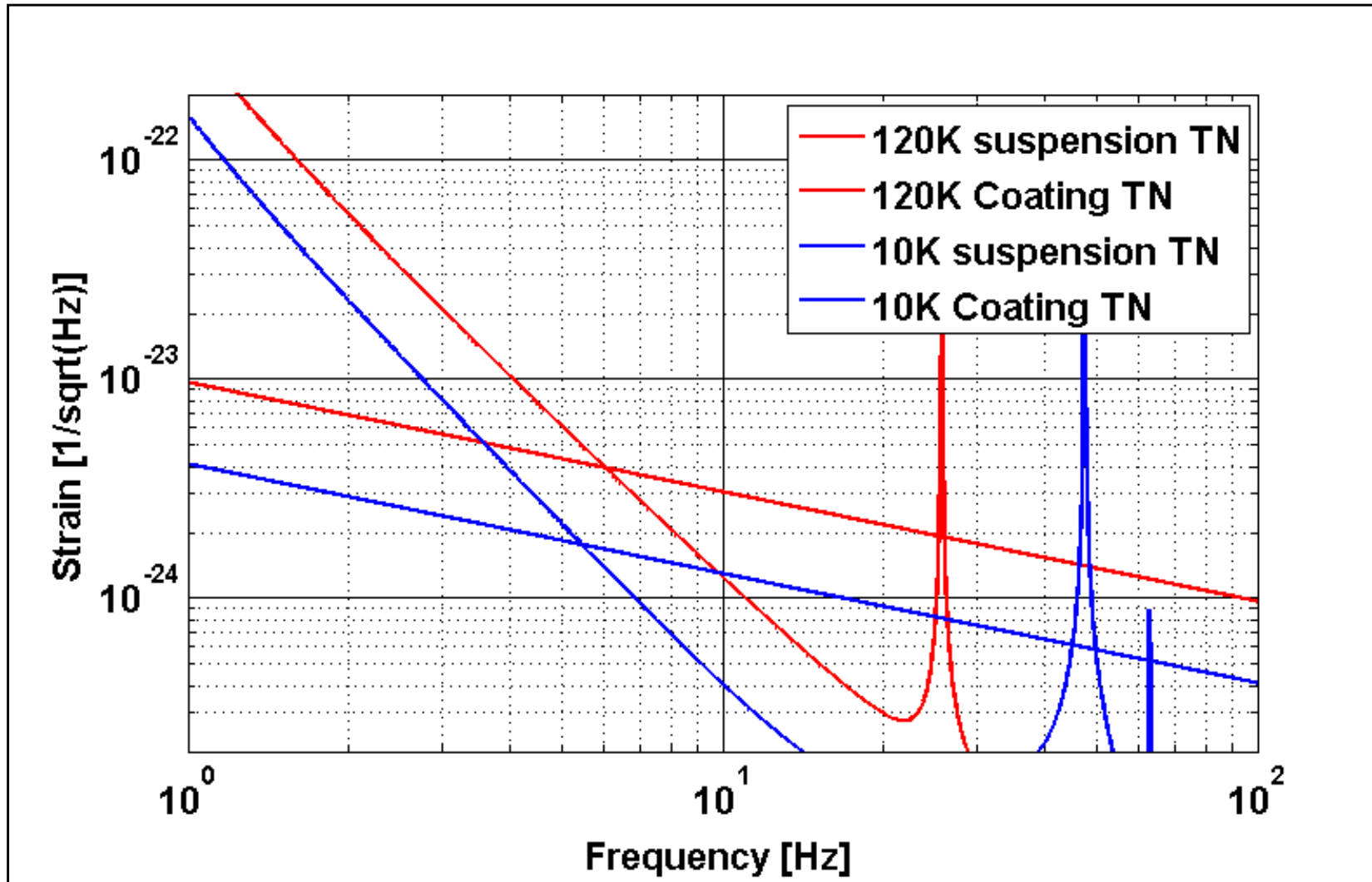

Assumes 160kg silicon test masses. Minimal fibre diameter / ribbon thickness is given by the required heat extraction for the 10K scenario and by the tensile strength for the 120K case.



How about a xylophone?

As H2 will go abroad, why not thinking about first building a Team Red like room temperature interferometer as H1 and then accompanying it with a cryogenic, low-power, low-frequency interferometer as H2?





General advantages of Xylophone concept

- ➔ Resolves the problem of noise sources scaling in opposite direction (e.g. **shot noise versus radiation pressure noise**).
- ➔ Resolves problem of **high power** laser beams on **cryogenic** test masses.
- ➔ Please note: It is already quite amazing that our detectors can span a detection band of 2 to 3 decades in frequency.
- ➔ However, it seems likely that at some point we will find it **easier** (in terms of complexity) and **cheaper** (in terms of cost and time) **to build two simpler interferometers** (each optimised for the noise sources relevant in its frequency range) rather than one extremely complex instrument (optimised for 'everything').



Let's build a xylophone inside the LIGO infrastructure ...

- ➡ For all xylophone considerations we neglect gravity gradient noise, seismic noise and any control noises or other technical noises.
- ➡ Our first approach is to use parameters very similar to the low frequency interferometer of ET:
 - 18kW of optical power impinging on the main mirrors
 - A monolithic silicon suspension that allows to extract at least the required 18mW
 - Silicon test masses of 40K
 - Tuned Signal recycling
 - Frequency dependent squeezing
 - etc



Thermal noise of a cryogenic Silicon suspension

- Allows to extract the power similar to ET-D-LF:
 $18\text{kW} * 1\text{ppm} = 18\text{mW}$
- Cryogenic silicon suspension at 40K.
- Improvement of about factor 10 at 10Hz.
- Stress was chosen to be half of the current (quick) lab measurement.
- Temperature was chosen as a compromise of heat extraction and TN performance.

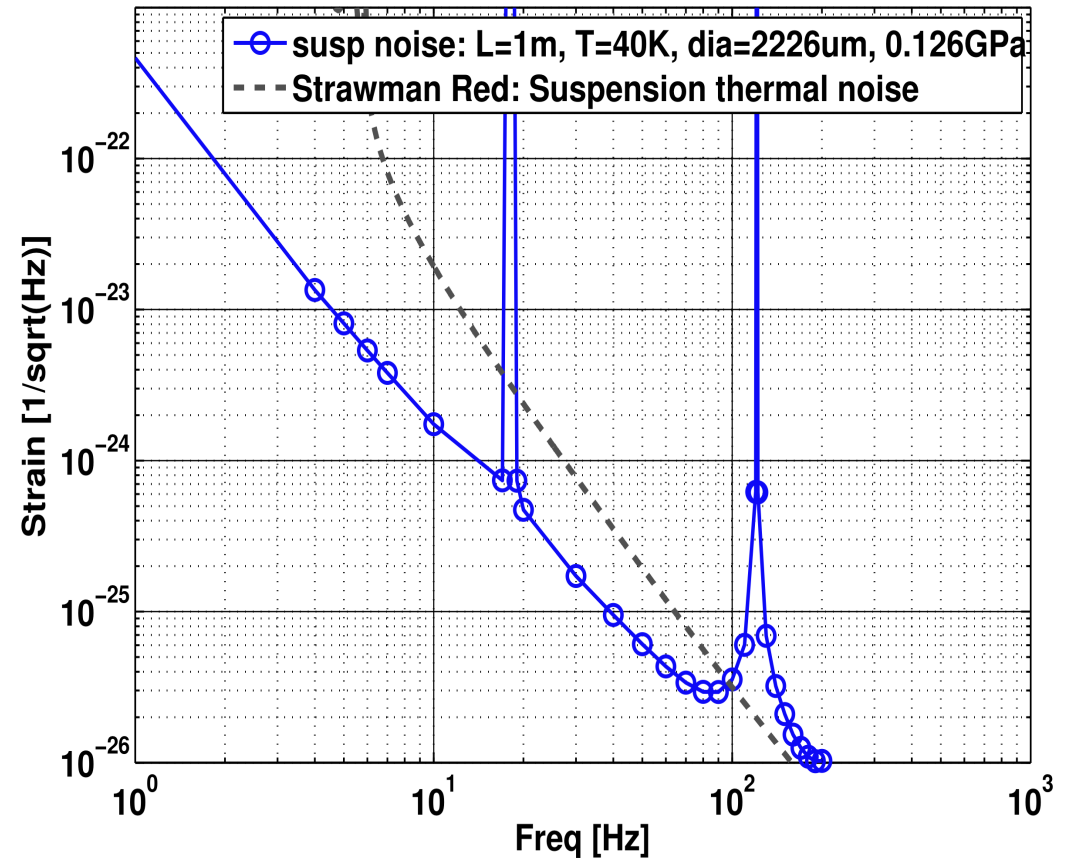



Coating noise of a cryogenic Silicon test mass

- ➔ **Assumes no better than tantala/silica coating on silicon substrate (conservative choice)**
- ➔ Uses measured losses for the coating materials
- ➔ Beam radius of 9 cm.

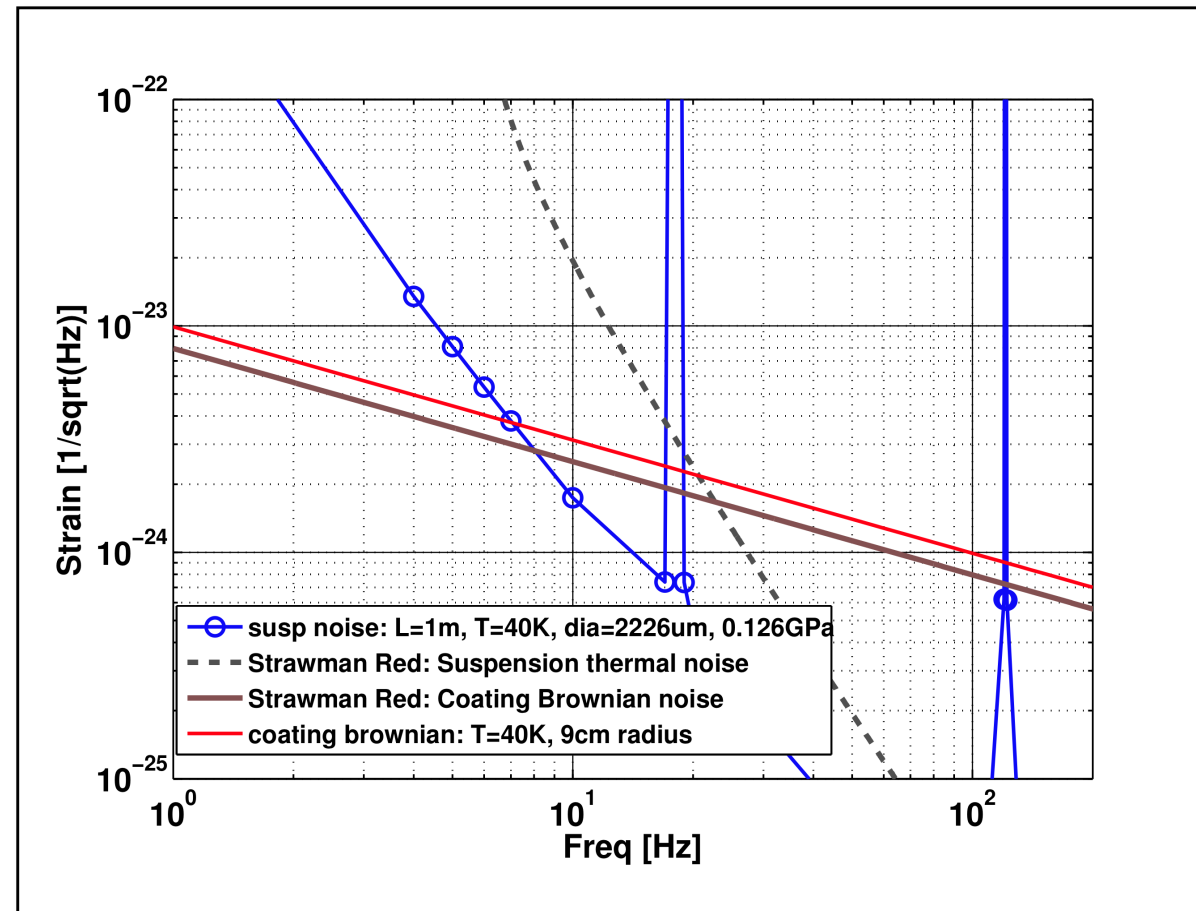



Quantum noise

- Assumed:
 - 18kW of circulating power
 - 1550nm
 - test masses of 160kg
 - effective squeezing of 10dB
- FPMI without Signal recycling
- This allows to get away with a single short filter cavity

Examples of different SR configurations from ET-D_LF

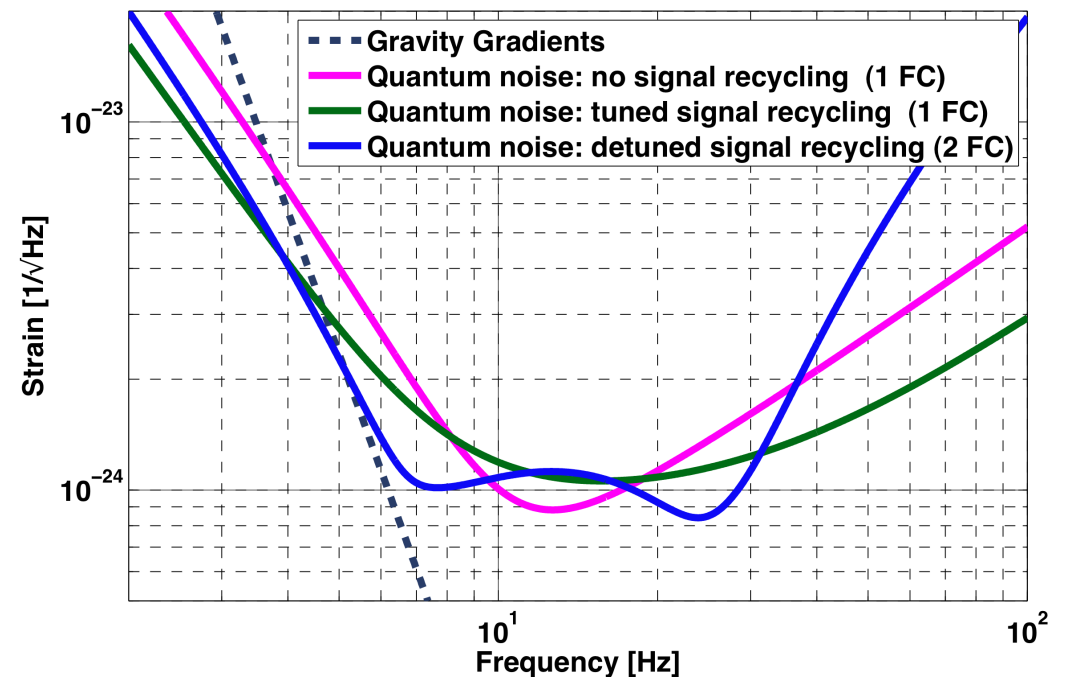



Noise budget of a cryogenic low-frequency detector

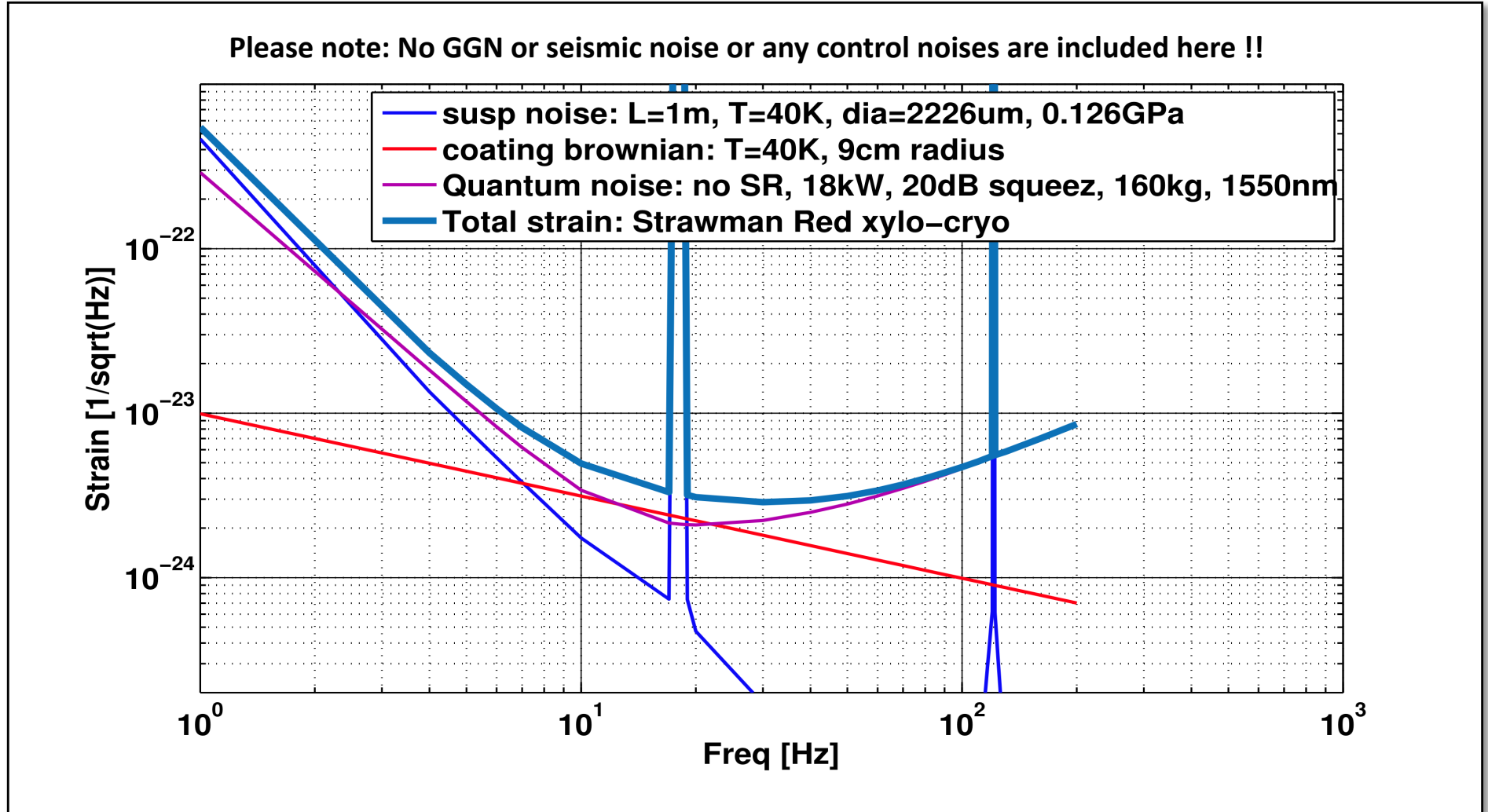



The full xylophone

Please note: No GGN or seismic noise or any control noises are included in the LF detector noise budget !!

Potential improvement

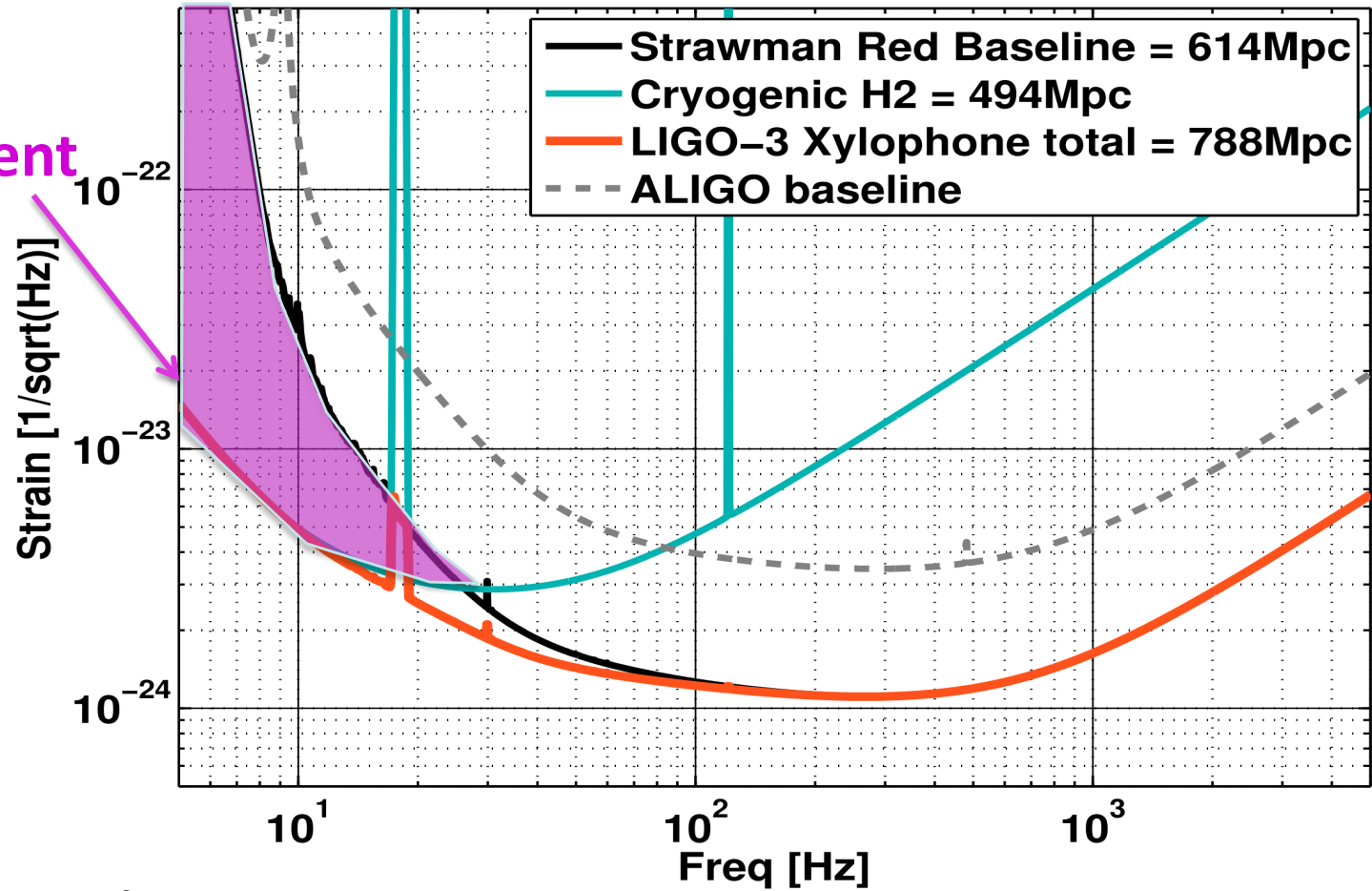

Numbers given in the legend refer to binary neutron star inspiral range.
A lower cut-off frequency of 5Hz was chosen.



Contents

- ➔ Background / Introduction
- ➔ Description of the Team Red design
- ➔ Discussion of a xylophone option
- ➔ What can we learn from all this?



What can we learn from this? (I)

- ➔ Advanced LIGO is far away from its facility limits.
- ➔ The Team Red design would allow an **incremental upgrade**, improving the **sensitivity broadband** by a factor 3-4.
- ➔ 'You can buy sensitivity at a rate of the order of about 10Mpc/\$1million'.
- ➔ However, it might be hard to further improve the instruments.

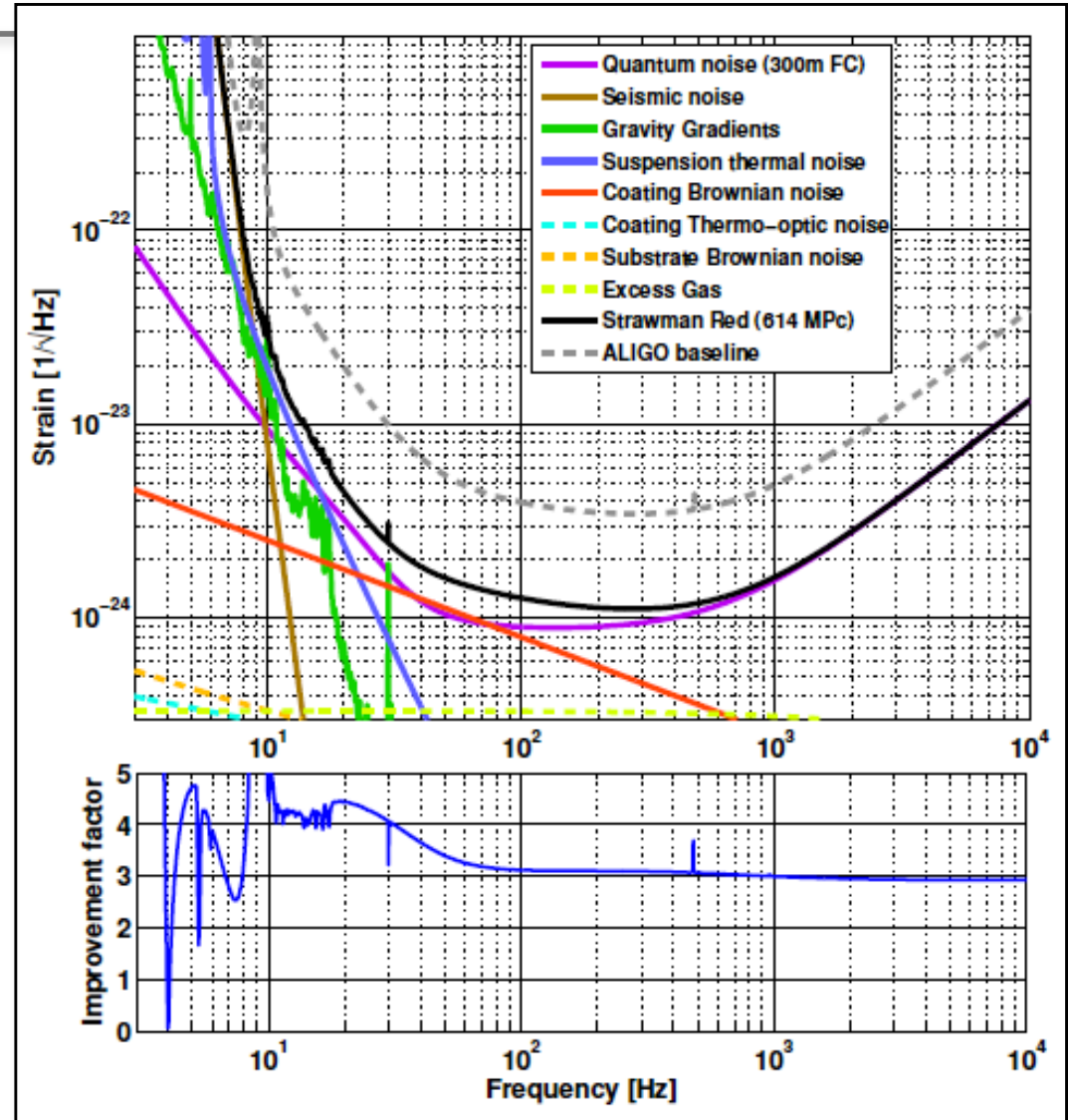



What can we learn from this? (II)

- ➔ **If we are prepared to do without the magic factor of 2 in coating noise improvement, then:**
- ➔ We still get a substantial sensitivity improvement to a BNS range of 430Mpc.
- ➔ But even more importantly: **Such a design would only include techniques and know-how that we already have! In principle we could start building such an interferometer right away.**

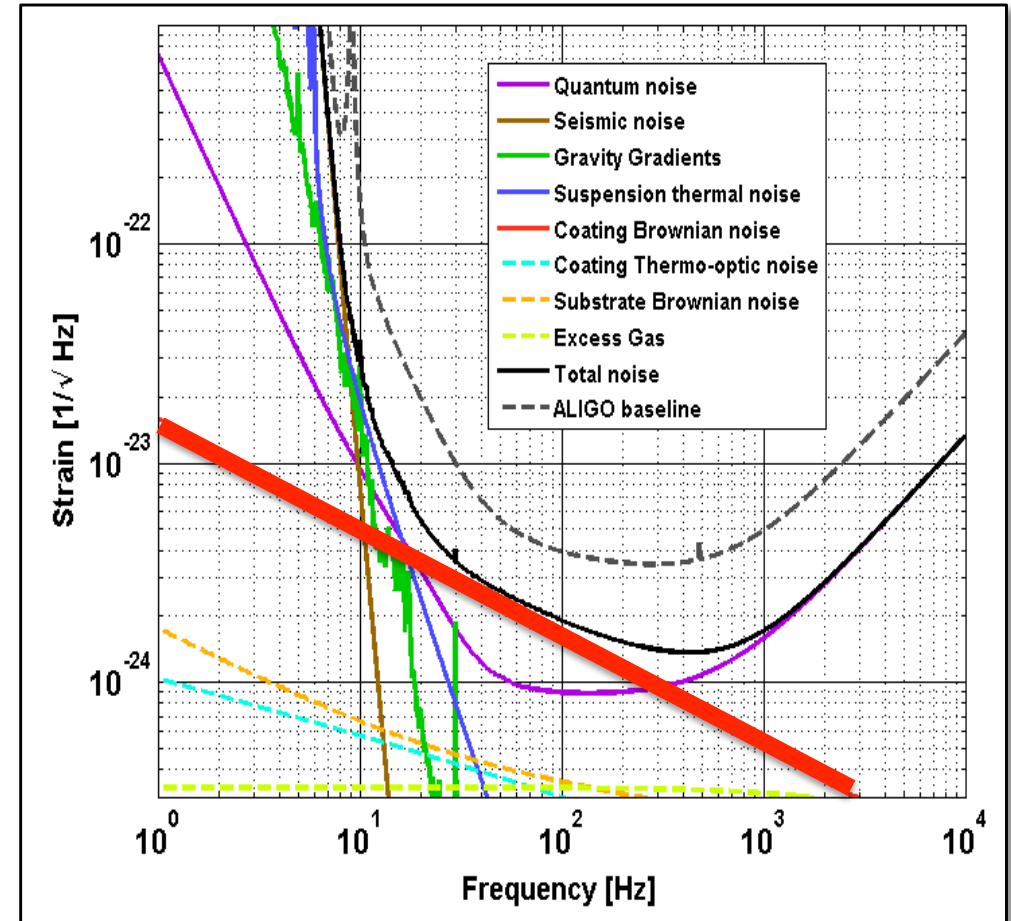



What can we learn from this? (III)

- If gravity gradient noise and seismic noise can be mitigated, a **cryogenic** instrument accompanying a RT partner could make a **significant low frequency sensitivity improvement**
- Using a xylophone can allow **simplifying the accompanying room temperature upgrade** (for instance shorter suspensions, lower weight of test masses, shorter filter cavity etc)
- Going for a full xylophone can give **all the benefits of a cryogenic, low-power interferometer** to cover the low frequency range while AT THE SAME TIME give the **full benefit of a not too complex high-power interferometer covering the high frequency** end.



The final thought ...

Doing a xylophone would allow us:

- ➔ **to have a safe, solid and cost efficient improvement of the sensitivity based on the room temperature interferometer.**
- ➔ while at the same time adding a cryogenic interferometer in the 10-40K range will **significantly improve the low frequency range** and (equally important) gives us the possibility **to learn cryogenics and prepare ourselves for the future.**



TOP 5: Required Research for Red Team Design

- ⇒ Common items with Blue and Green Design: Large optics, heavy suspensions, Newtonian noise subtraction, low-loss squeezing injection.
- ⇒ **Better coatings:** Room temperature + cryogenics, 1064nm + ~ 1.5 micron (waveguide mirrors + Khalili cavity as a backup plan)
- ⇒ **Xylophone** concept and how to integrate it into infrastructure
- ⇒ **Silicon material parameters** (Sapphire as a backup)
- ⇒ **Quasimonolithic design** for cryogenic silicon suspension including heat extraction.



EXTRA SLIDES



Increasing the beam size

- ➔ Assume an **increase of beam size by a factor 1.6.**
- ➔ Keep aspect ratio of test masses as it is => 160kg.
- ➔ Reduces all mirror thermal noise contributions by a factor 1.6.

Parameter	Advanced LIGO	Strawman Red Design
ROC of ITM [m]	1934	1849
ROC of ETM [m]	2245	2173
cavity length [m]	3996	3996
spot size at ITM [cm]	5.31	8.46
spot size at ETM [cm]	6.21	9.95
mirror diameter [cm]	34	55
waist position [m]	1835	1835
waist size [cm]	1.20	0.74
g-factor of arm cavity	0.832	0.974

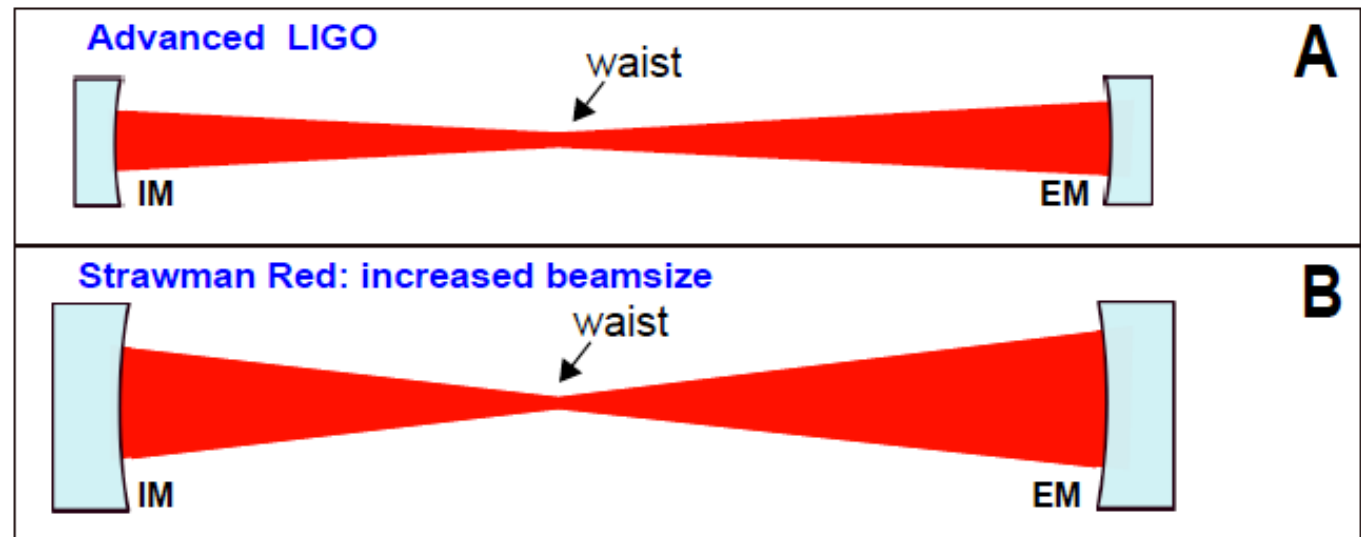



Optical coatings with reduced thermal noise

- ➔ Continued **improvement of tantala** coatings.
 - Loss related to local atomic structure of material
- ➔ High-temperature **annealing** of coatings.
 - Heat treatment in the range of 500-1000 degrees centigrade
- ➔ **Amorphous silicon** as a high-index coating material
 - $n=3.5 \Rightarrow$ quarter-wave layer is thinner. In addition need fewer layers.
 - Potential improvement = 2.1 (in amplitude)
 - Requires change of laser wavelength
- ➔ **Crystalline** coatings (e.g. AlGaAs or AlGaP)



Khalili cavities

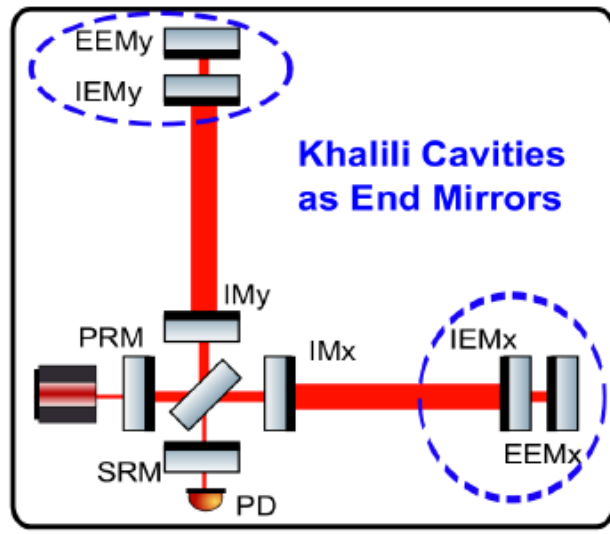

Reducing thermal noise in future gravitational wave detectors by employing Khalili etalons

Alexey G. Gurkovsky^a, Daniel Heinert^b, Stefan Hild^c, Ronny Nawrodt^b, Kentaro Somiya^{d, e}, Sergey P. Vyatchanin^a, Holger Wittel^f

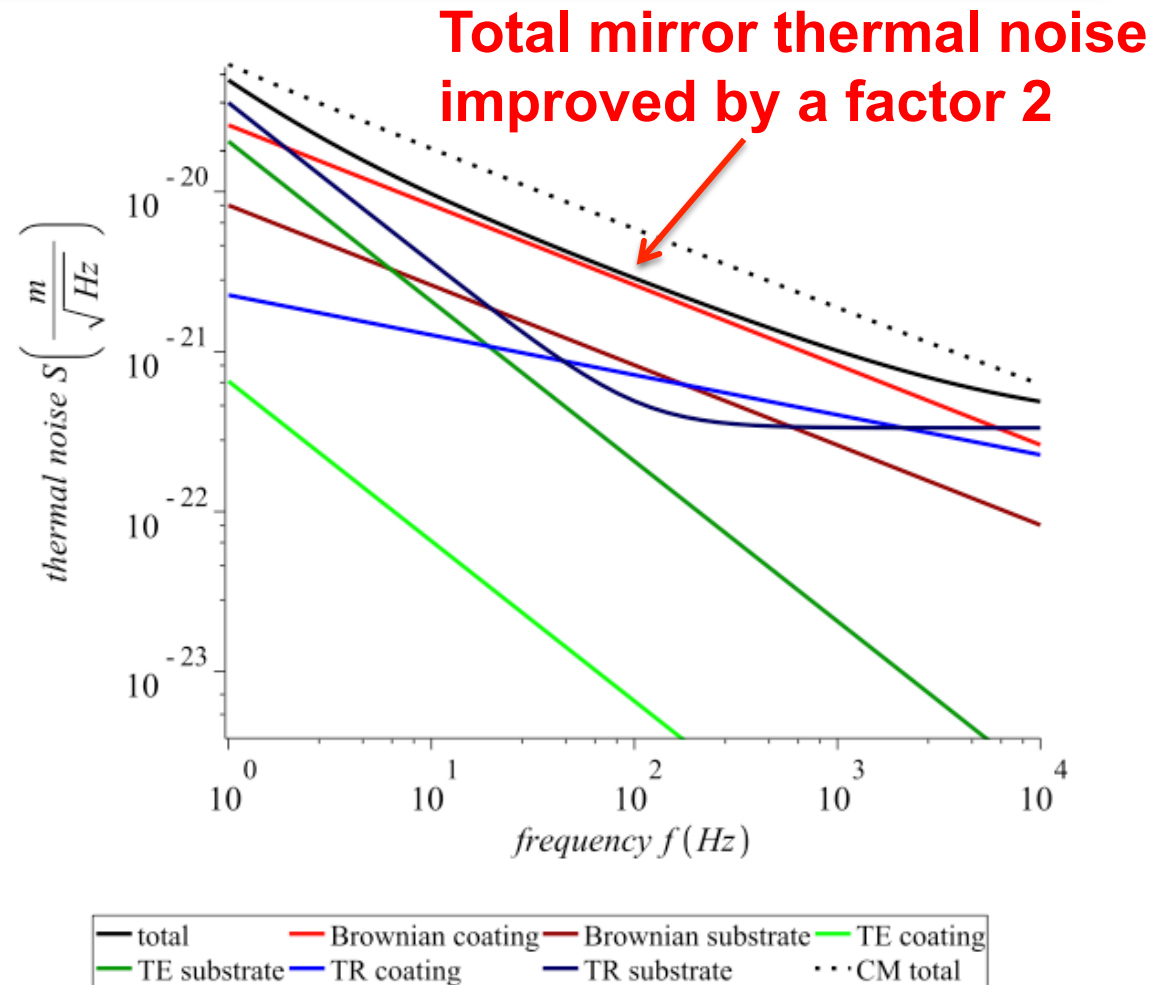



Waveguide mirrors

Factor of 2 lower total noise

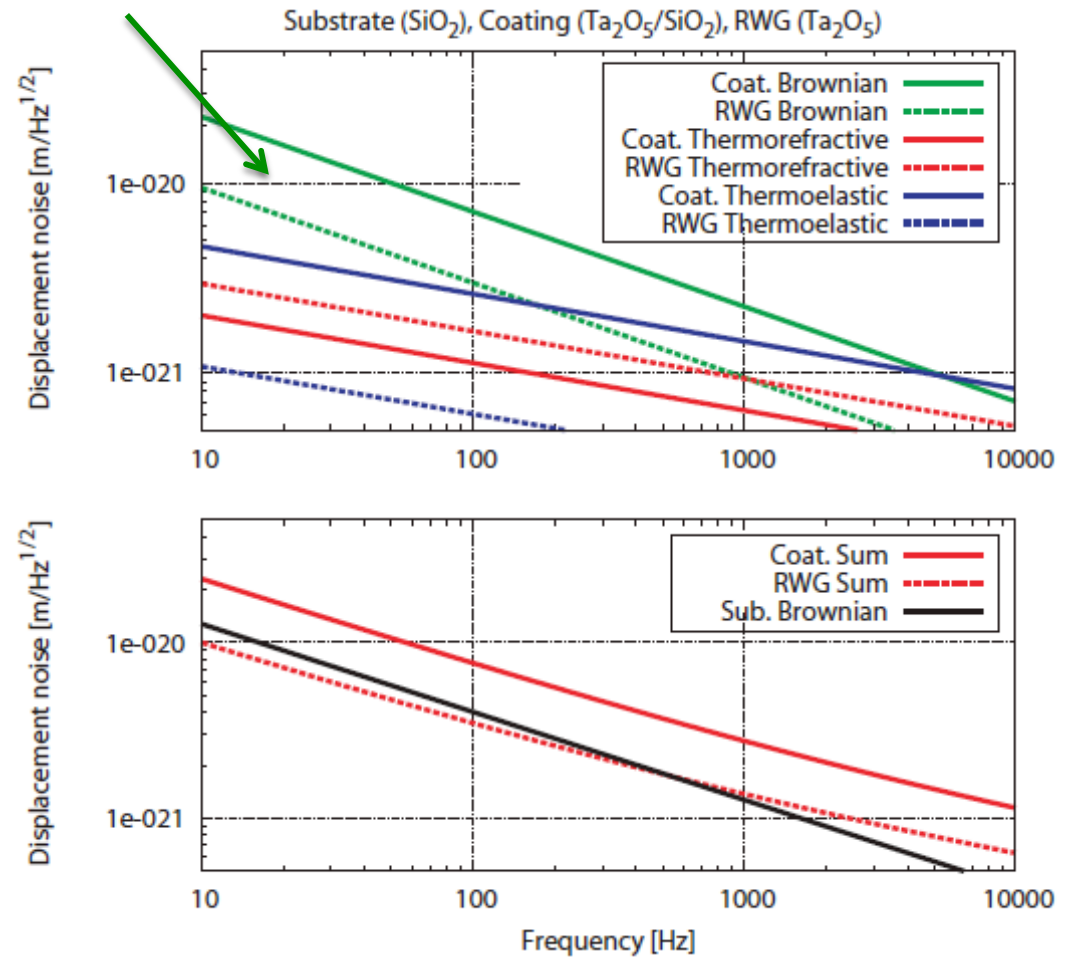
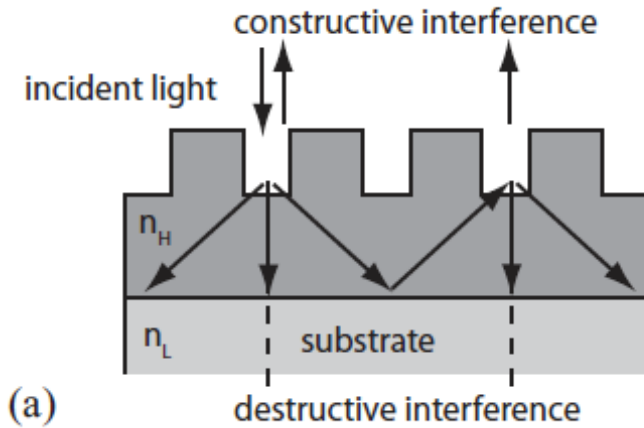

From D. Friedrich PhD thesis



Squeezing losses

- Generation of squeezing: 3 %
- Optical isolation: 3 x 0.8 %
- Mode matching to IFO and to OMC: 2 x 1 %
- OMC loss and QE of PD: 2 x 0.5 %
- Mode matching to filter cavity: 1 %

= 9% in total

Cavity losses in literature

Length [m]	Loss per mirror [ppm]	Year
10	60	1984 [61]
0.004	1.1	1992 [62]
0.202	1.5	1996 [63]
0.202	1.6	1998 [64]
20	30	1999 [?]

Filter cavity length [m]	500	300	200	100	50
Input mirror power transmittance [ppm]	704	422	281	141	70
Binary neutron star inspiral range [Mpc]	640	613	584	521	455

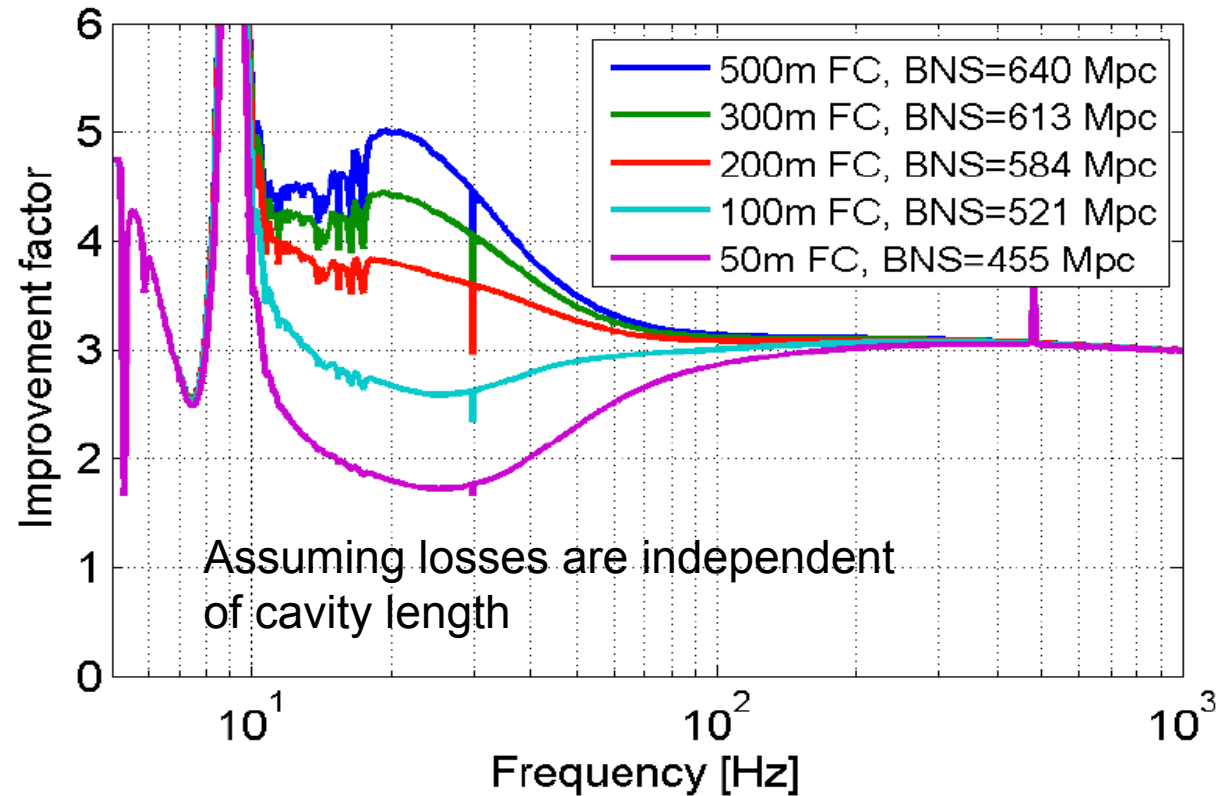



Newer data from LLO

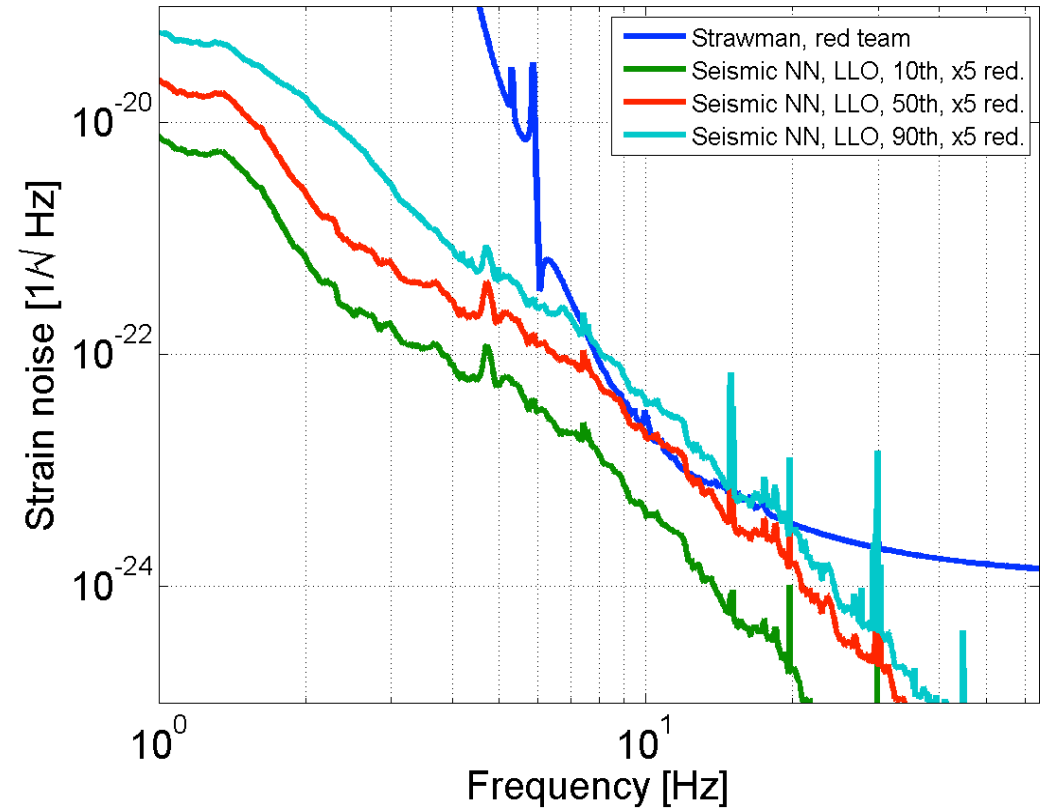
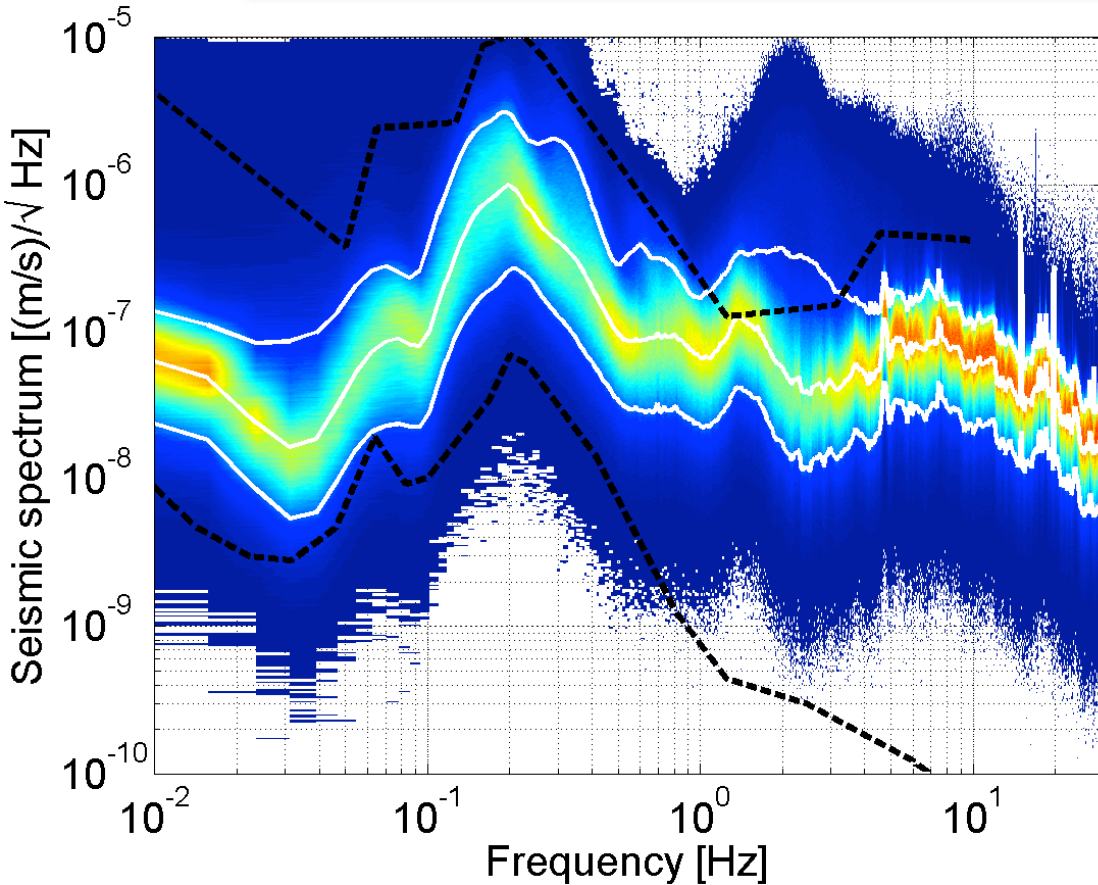

New data from LLO seem to suggest that Strawman red underestimates the GGN level by about a factor 2.



Khalili cavities

- ➔ Extremely hardware intensive.
- ➔ Lots of technical challenges:
 - Thermal lensing
 - Cavity stability
 - Control

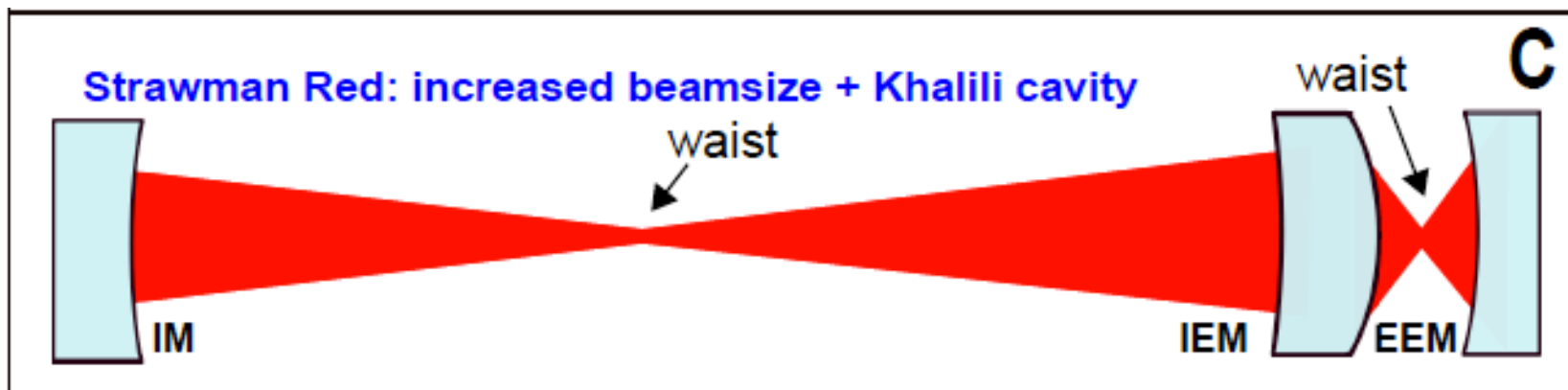
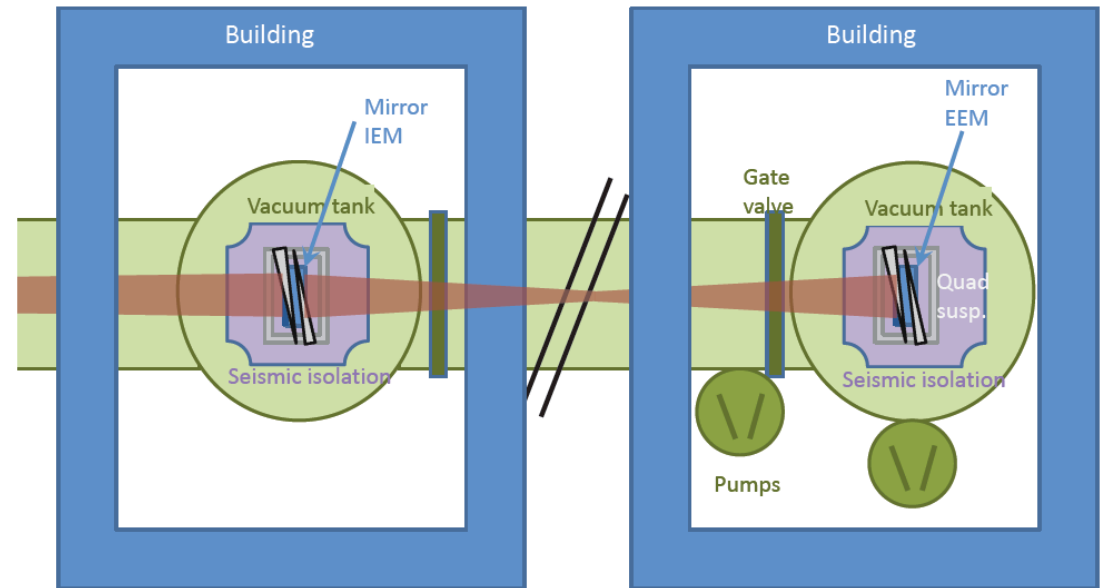



Thermal lensing in K-cavity

Khalili cavity

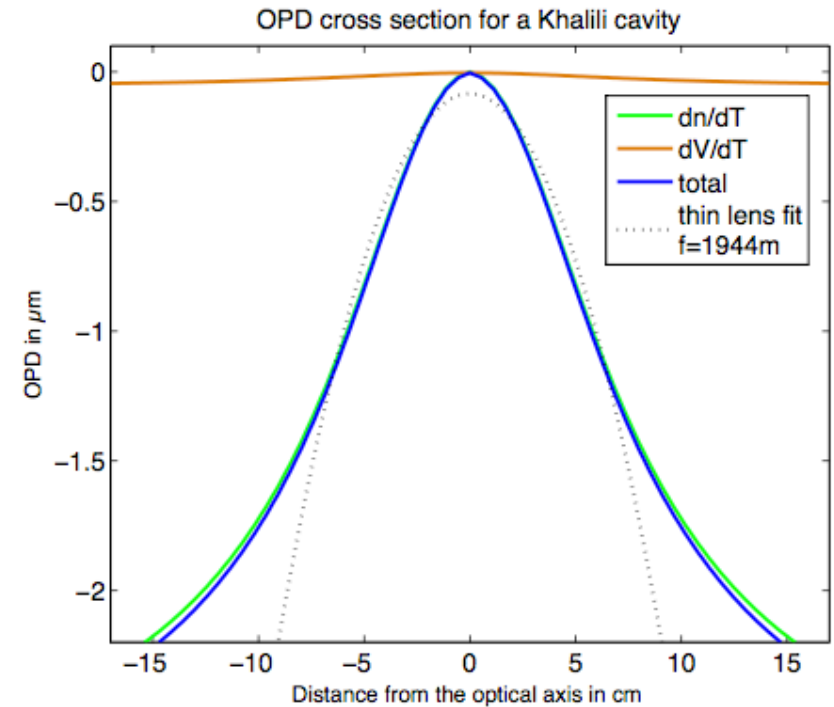
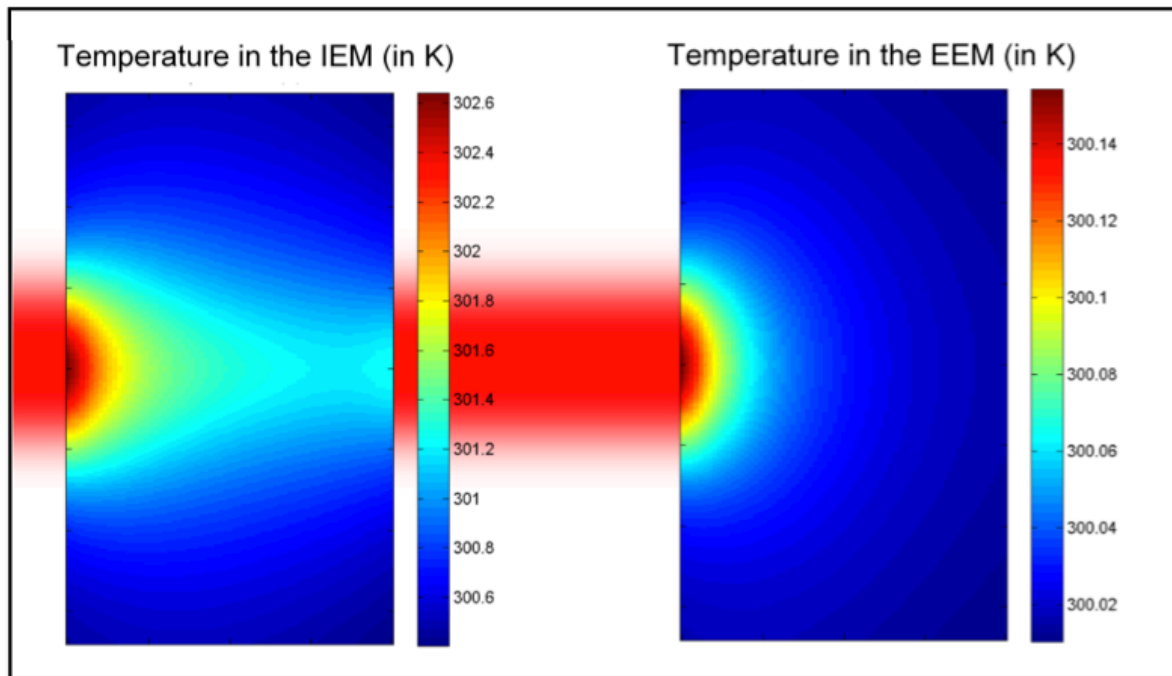

Reducing thermal noise in future gravitational wave detectors by employing Khalili etalons

Alexey G. Gurkovsky^a, Daniel Heinert^b, Stefan Hild^c, Ronny Nawrodt^b, Kentaro Somiya^{d, e}, Sergey P. Vyatchanin^a, Holger Wittel^f



Speedometer an alternative?

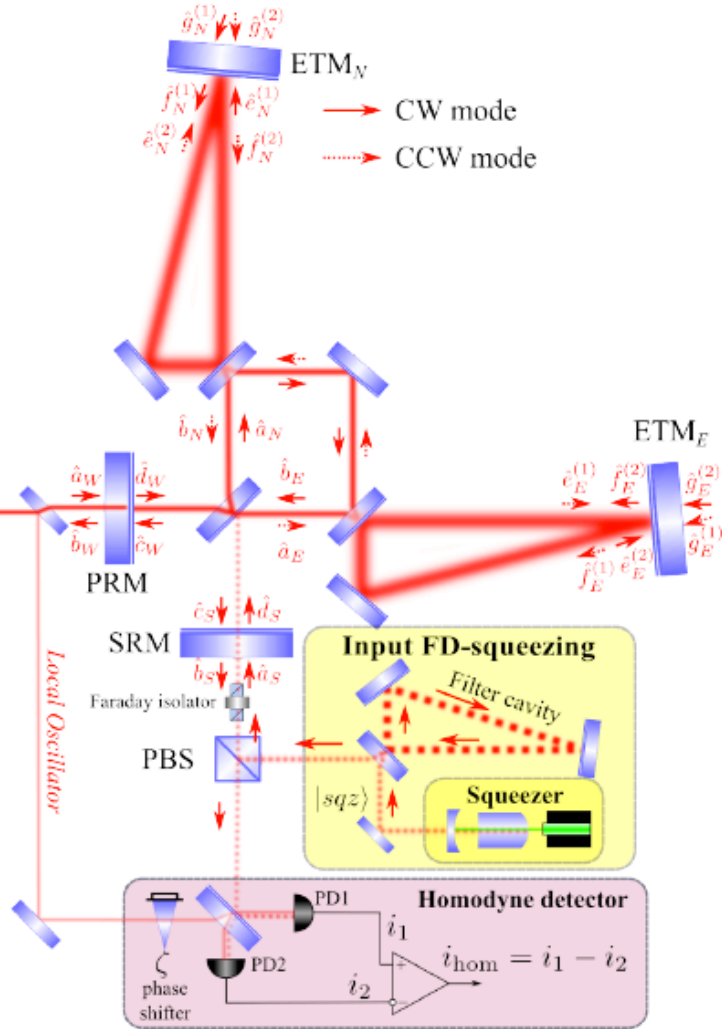
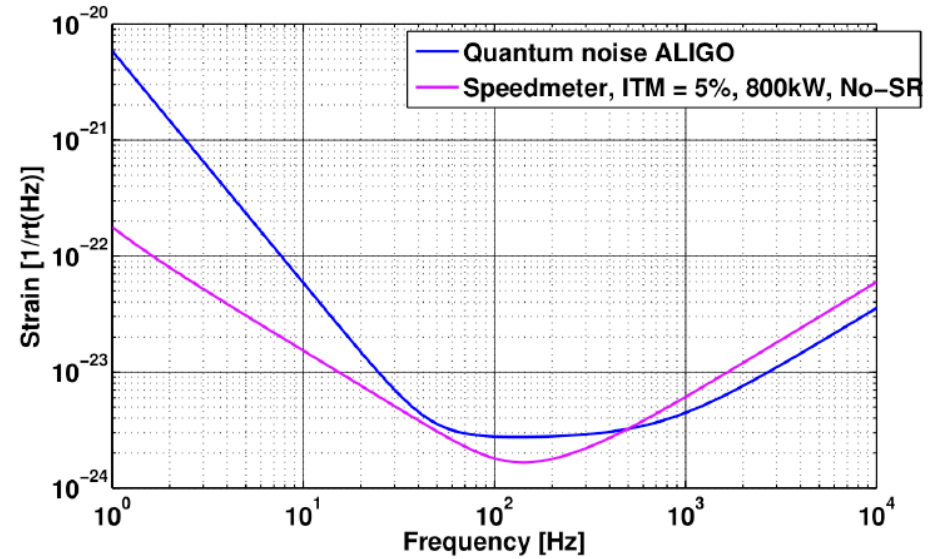

Parameter	Description	Value (4-km filter cavity)	Value (100-m filter cavity)
M	Mirror mass	40 kg	40 kg
L	Arms length	3995 m	3995 m
λ_0	Laser wavelength	1.064 μm	1.064 μm
P_c	Power in arms	$2 \times 750 \text{ kW}$	$2 \times 750 \text{ kW}$
η	quantum efficiency of PD	95%	95%
ϵ_{arm}	round-trip loss in arms	40 ppm	40 ppm
ϵ_{FC}	round-trip loss in FC	40 ppm	40 ppm
ζ	optimal homodyne angle	6.43 degrees	15 degrees
e^{2r}	squeezing factor	10 dB	10 dB
ψ_0	constant squeezing phase shift	6.46 degrees	15.5 degrees
T_{ITM}	ITM power transmissivity	0.052	0.06
$\tau_{\text{SRM}} = 1 - \rho_{\text{SR}}$	SRM power transmissivity	0.89	0.9
ϕ_{SRC}	SR cavity detune phase	90	73.7 degrees
T_f	FC input mirror power transmissivity	0.017	0.023
L_f	FC length	3.995 m	100 m
$\gamma_f = \frac{cT_f}{4L_f}$	FC half-bandwidth	$2\pi \times 49 \text{ sec}^{-1}$	$2\pi \times 540 \text{ sec}^{-1}$
δ_f	FC detuning	$2\pi \times 32 \text{ sec}^{-1}$	$2\pi \times 255 \text{ sec}^{-1}$



How to properly optimise the cryo interferometer?

Optimisation concept & Matlab Functions

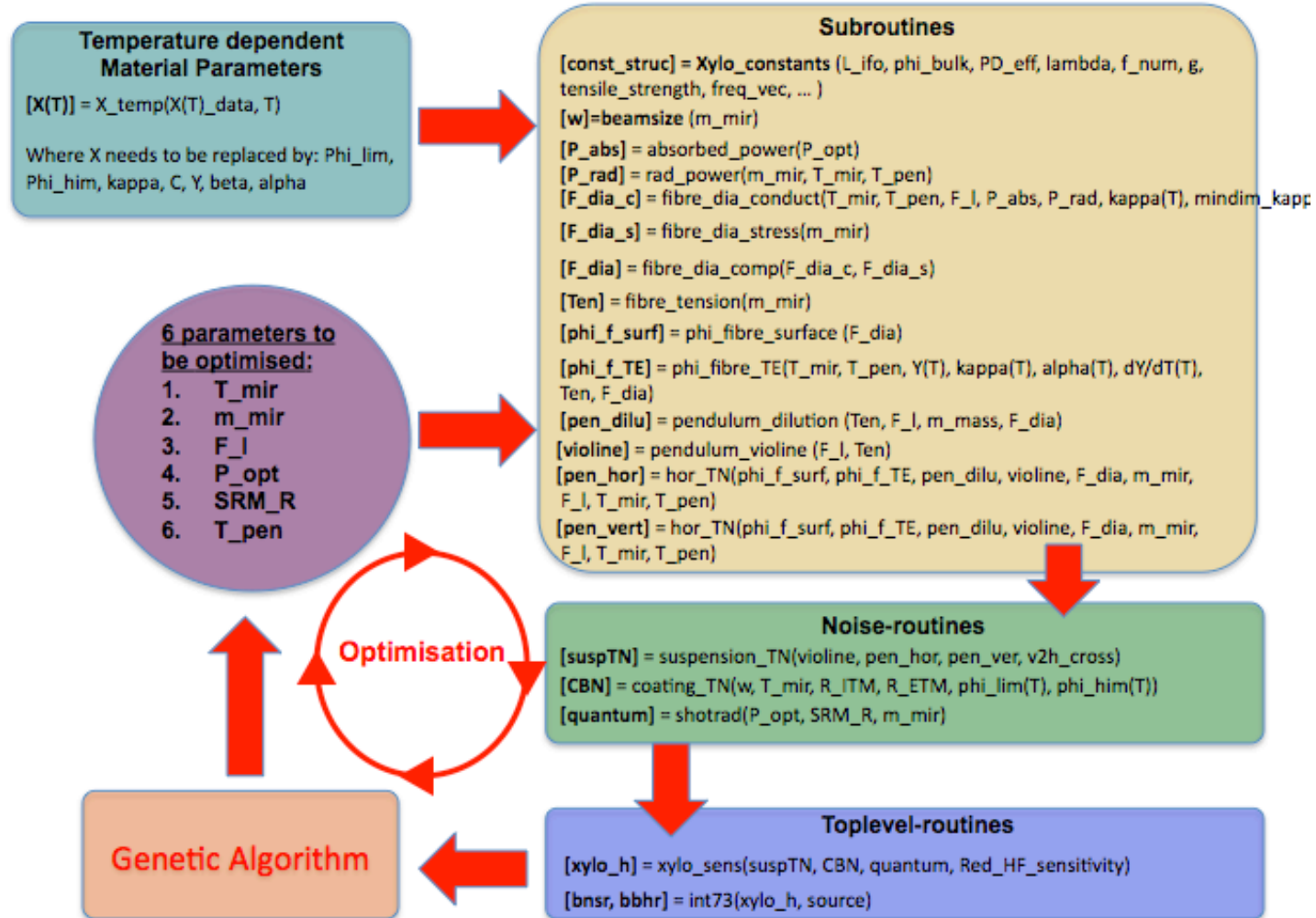



aLIGO with 10km armlength

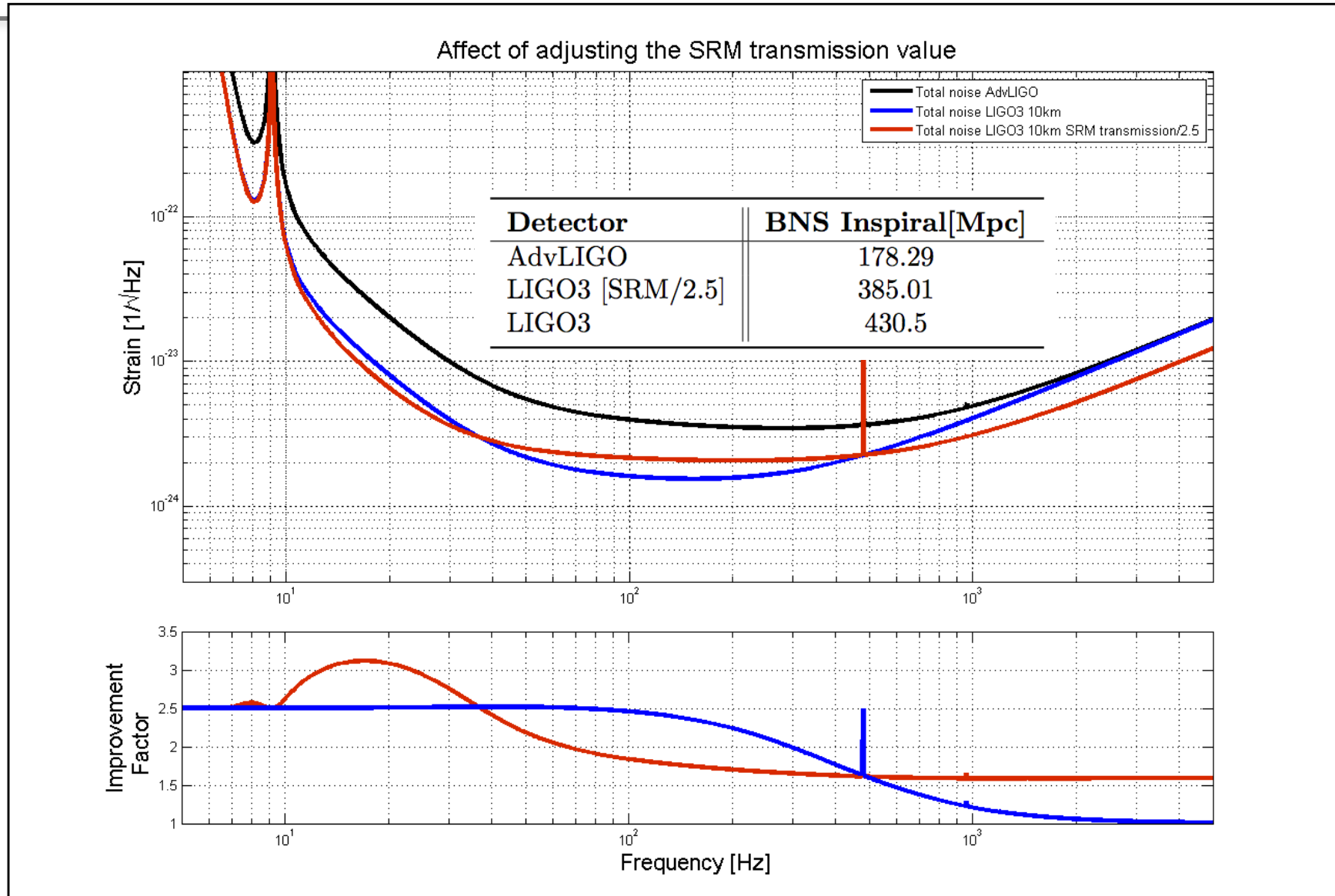

Credit:
J.MacArthur & N.Gordon