

Advanced LIGO: Next Steps and Future Improvements

Stefan Hild for the LSC

LIGO-G1200598





Contents

- ➔ Background / Introduction
- ➔ A Zoo of technologies to reduce individual noise sources.
 - Suspension thermal noise
 - Gravity gradient noise
 - Mirror thermal noise
 - Quantum noise
- ➔ Example upgrade 1: Team Red design
- ➔ Example upgrade 2: Team Blue design
- ➔ Example upgrade 3: Team Red Xylophone
- ➔ What can we learn from all this?



Introduction

- ➔ With 2nd generation instruments under construction (*See talks by Reitze, Fafone, Lueck, Shoemaker and Somiya*) it is now time to look what comes afterwards.
- ➔ In Europe the design study for the third generation **Einstein telescope** (based on an underground xylophone with 10km armlength) has been completed (*See talk by Punturo in GW4*).

<https://tds.ego-gw.it/itf/tds/index.php?callContent=2&callCode=8709>

- ➔ **What are the upgrade options for Advanced LIGO?**

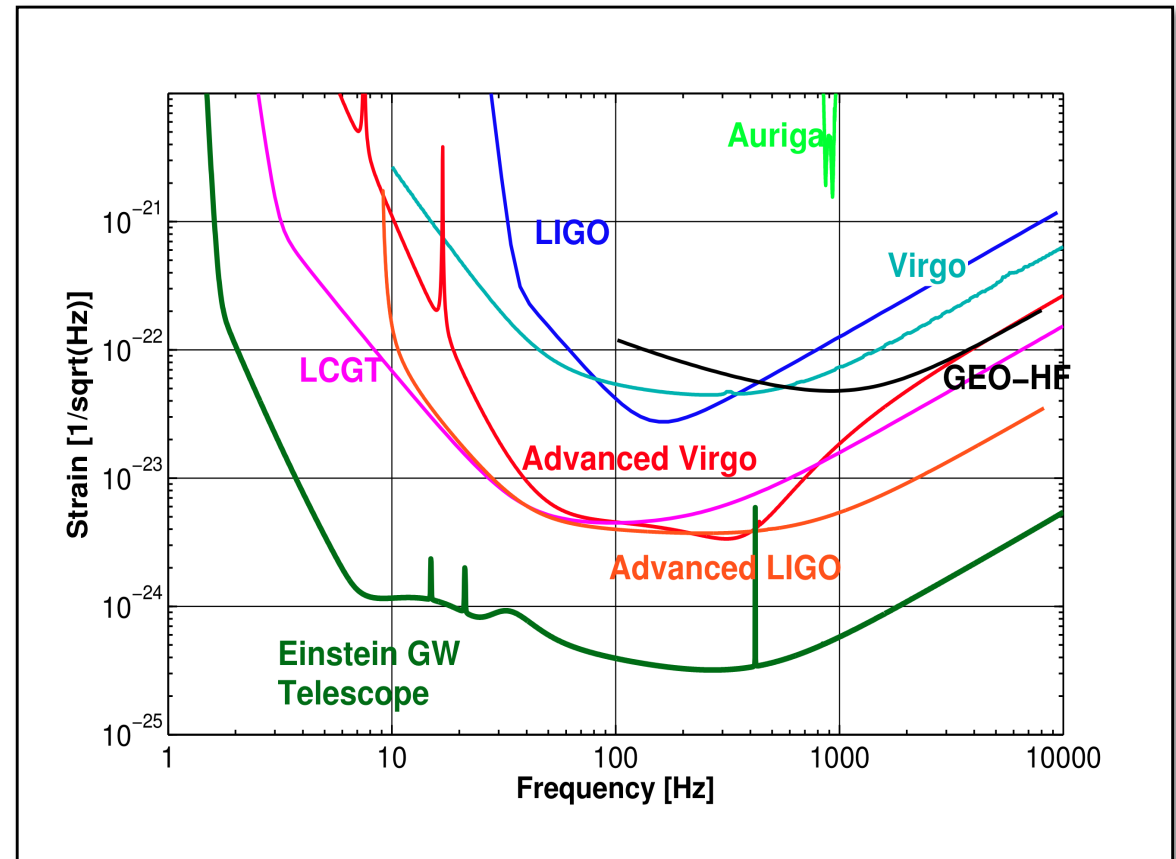



Motivation for Advanced LIGO upgrades

- ➔ The **advanced LIGO baseline detectors** are expected to accomplish the **first direct detection** of gravitational waves.
 - See talk by D. Shoemaker in this session
 - See also Abadie et al, CQG, **2010**, 27, 173001
- ➔ However, these observations are likely to be of modest signal-to-noise ratio (SNR). If we want to access the **full physics** of the sources we will **need to increase the SNR**.
- ➔ As we will see it seems possible to upgrade the aLIGO instruments gaining a **broadband sensitivity improvement by a factor of 3-5** (roughly equivalent to increasing the event rate by a factor 25-100).
- ➔ For details on the exciting science aLIGO upgrades will bring into our reach please see: **Adhikari et al: 'Astrophysical Motivations for the Third Generation LIGO Detectors', LIGO-T1200099-v2**



Noise Sources limiting the Advanced Detectors

- ➔ In order to understand how we can potentially improve 2G detectors, we need to see what they are limited by:
- **Quantum Noise** limits most of the frequency range.
 - **Coating Brownian** limits (or is close) in the range from 50 to 100Hz.
 - Below 50Hz we are limited by 'walls' made of **Suspension Thermal**, **Gravity Gradient** and **Seismic noise**.

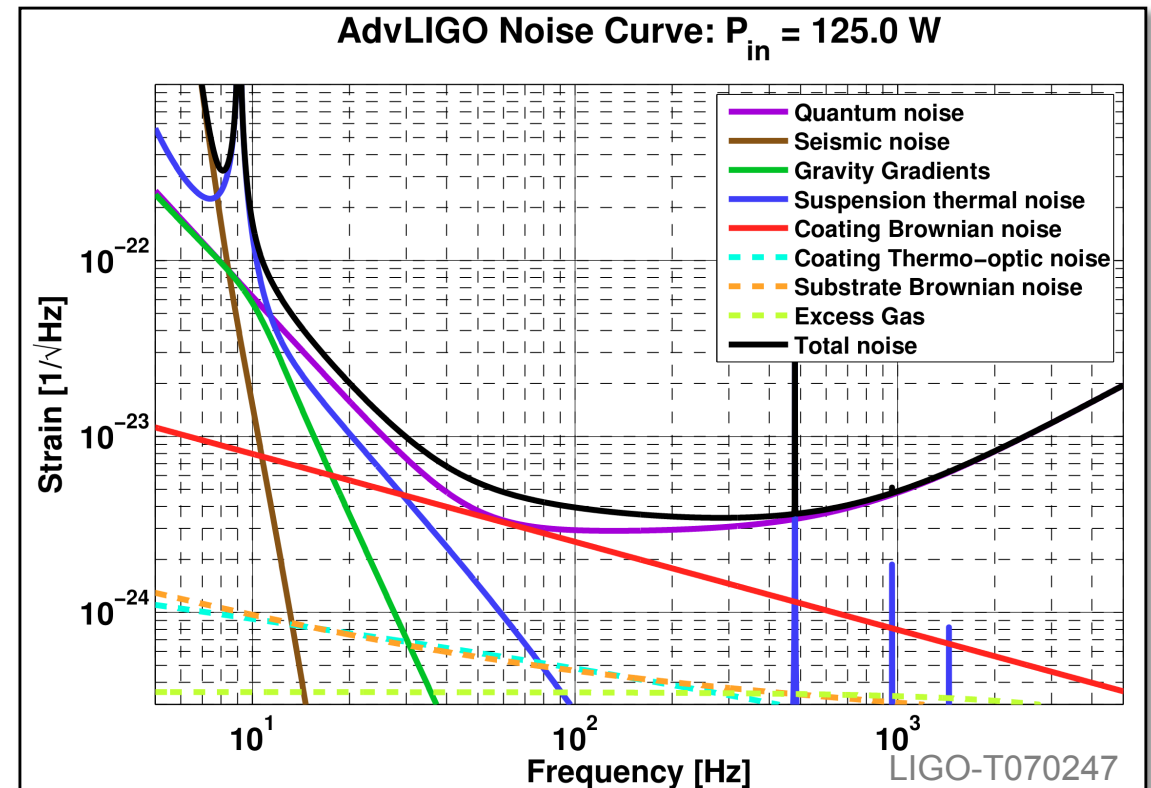



Upgrades within the Advanced LIGO infrastructure

- ➔ The advanced LIGO baseline sensitivity is far away from the **infrastructure limits**.
- ➔ Infrastructure limit is usually defined as combination of residual gas noise and gravity gradient noise.
- ➔ **So there is plenty of room for advanced LIGO upgrades within the existing infrastructure! And this will be the focus of the rest of this presentation.**

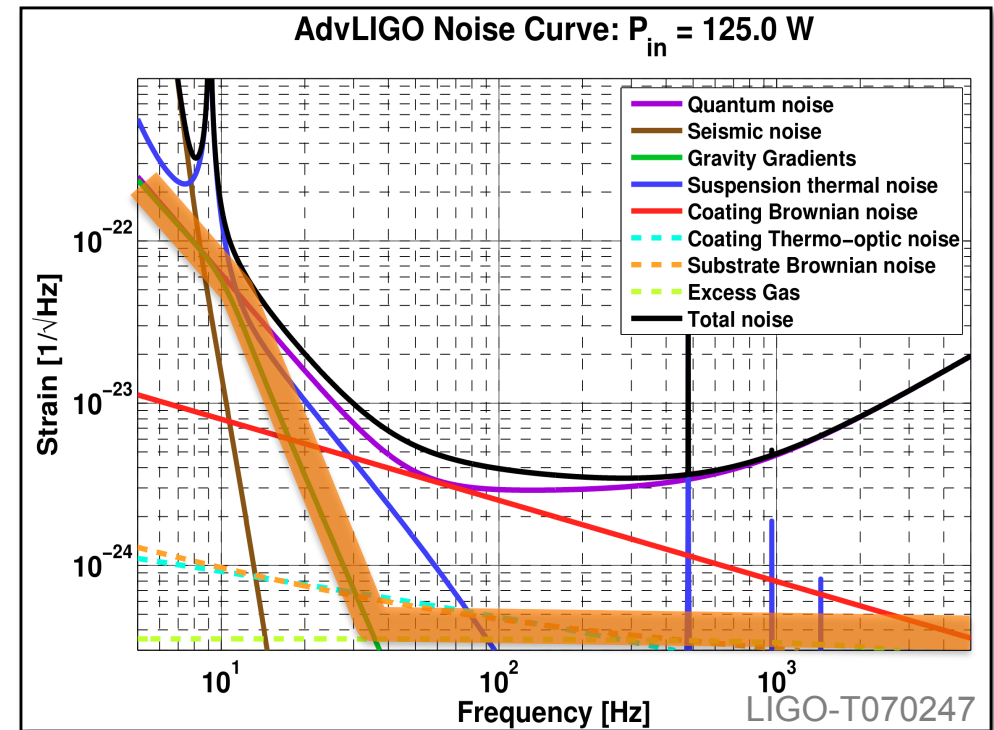



Strawman Exercise

- ➔ About a year ago the LIGO Scientific Collaboration decided to initiate an effort to develop simple design studies (so-called Strawman designs) for aLIGO upgrades.
- ➔ 3 teams formed: **Blue** (headed by R.Adhikari), **Green** (headed by S.Ballmer) and **Red** (headed by S.Hild).
- ➔ Some interesting aspects:

When do we need to be ready for the upgrades?

What R&D do we need to carry out over the next few years?

What is the available budget?

Can we do the upgrades in an incremental way?

How much improvement is possible?



Contents

➔ Background / Introduction

➔ A Zoo of technologies to reduce individual noise sources.

- Suspension thermal noise
- Gravity gradient noise
- Mirror thermal noise
- Quantum noise

➔ Example upgrade 1: Team Red design

➔ Example upgrade 2: Team Blue design

➔ Example upgrade 3: Team Red Xylophone

➔ What can we learn from all this?



Mirror Thermal Noise

- ➔ Due to thermal fluctuations the position of the mirror sensed by the laser beam is not necessarily a good representation of the center of mass of the mirror.
- ➔ Various noise terms involved: Brownian, thermo-elastic and thermo-refractive noise of each substrate and coating (or coherent combinations of these, such as thermo-optic noise).
- ➔ For nearly all current and future designs coating Brownian is the dominating noise source:

PSD of displacement

$$S_x(f) = \frac{4k_B T}{\pi^2 f Y} \frac{d}{r_0^2} \left(\frac{Y'}{Y} \phi_{\parallel} + \frac{Y}{Y'} \phi_{\perp} \right)$$

Temperature

Boltzmann constant

Geometrical coating thickness

Loss angle of coating

Young's modulus of mirror substrate

laser beam radius

Young's modulus of coating

Harry et al, CQG 19, 897–917, 2002



How to reduce Mirror Thermal Noise?

Improved coating materials (e.g. crystalline coatings like AlGaAs, GaPAs)

Cole et al, APL 92, 261108, 2008

Waveguide mirrors

Brueckner et al, Opt. Expr 17, 163, 2009

PhD thesis of D.Friedrich

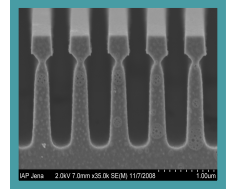

Larger beam size (needs larger mirrors)

Harry et al, CQG 19, 897-917, 2002

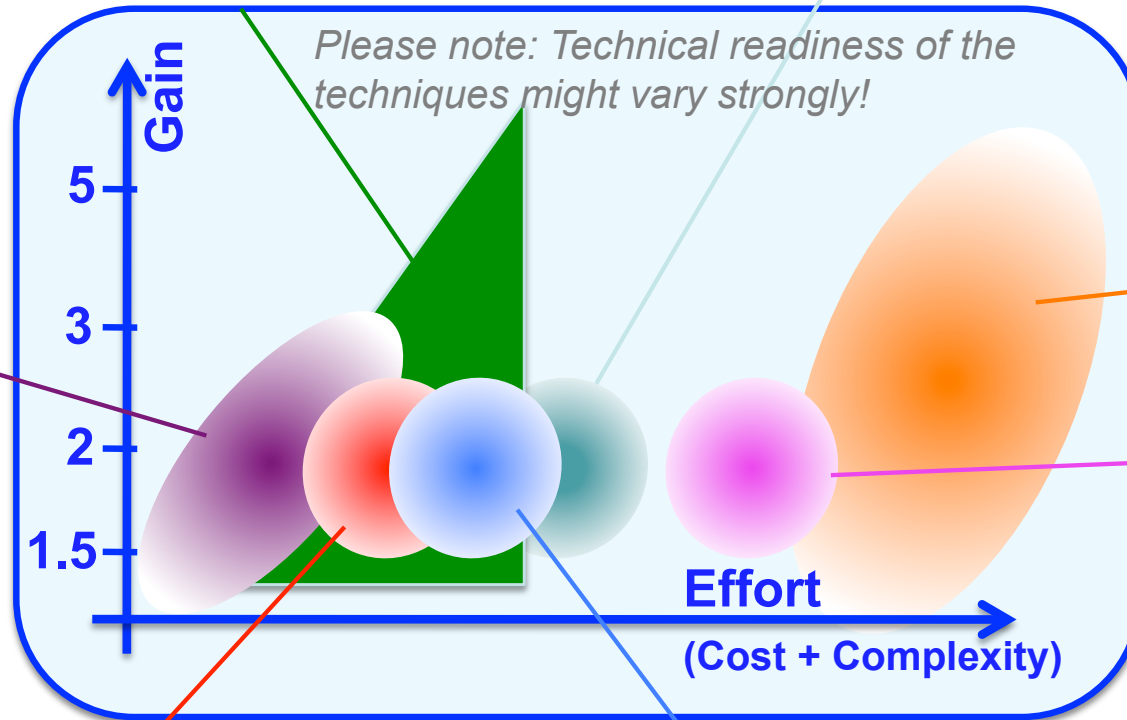

Cryogenic mirrors

Uchiyama et al, PRL 108, 141101 (2012)

Khalili cavities

Khalili, PLA 334, 67, 2005
Gurkovsky et al, PLA 375, 4147, 2011

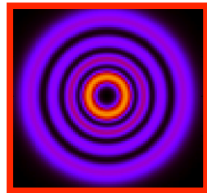

Different beam shape

Mours et al, CQG, 2006, 23, 5777

Chelkowski et al, PRD, 2009, 79, 122002

Amorphous Silicon coatings

Liu et al, PRB 58, 9067, 1998

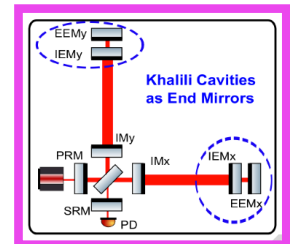



Suspension Thermal Noise

$$x^2(\omega) = \frac{4k_B T \omega_0^2 \phi(\omega)}{\omega m [(\omega_0^2 - \omega^2)^2 + \omega_0^4 \phi^2(\omega)]}$$

PSD of displacement

Boltzmann constant

Temperature

Loss angle

Mirror mass

Resonance frequency

- ➔ Mirrors need to be suspended in order to decouple them from seismic.
- ➔ Thermal noise in metal wires and glass fibres causes horizontal movement of mirror.
- ➔ Relevant loss terms originate from the bulk, surface and thermo-elastic loss of the fibres + bond and weld loss.
- ➔ Thermal noise in blade springs causes vertical movement which couples via imperfections of the suspension into horizontal noise.

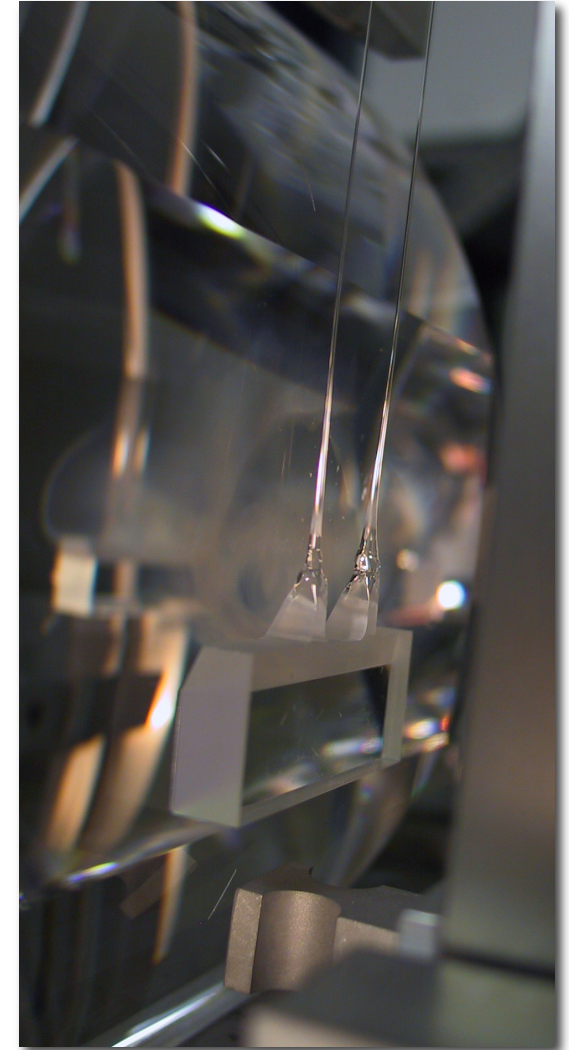



How to reduce Suspension Thermal Noise?

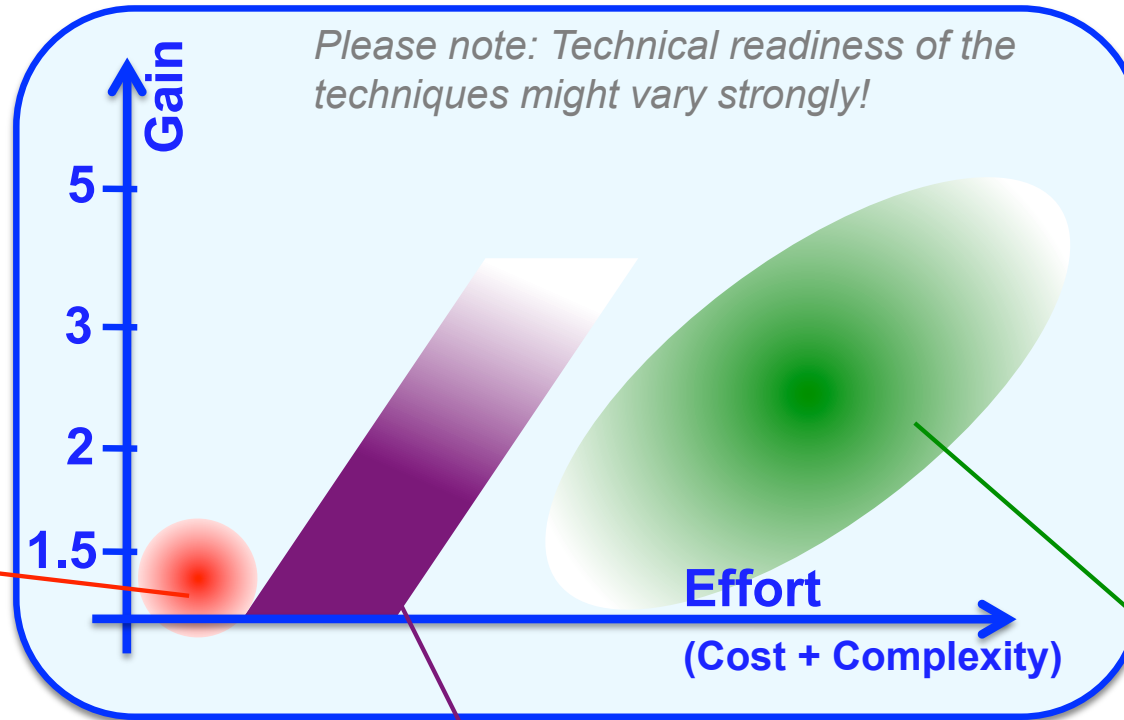

Improve fibre geometry/profile

Bending points, energy stored via bending and neck profile can be potentially further optimised.

Increase length of final pendulum stage.

Allows the push suspension thermal noise out detection band.

Cooling of the suspension to cryogenic temperatures.
Usually also requires a change of materials.



Gravity Gradient Noise (also referred to as Newtonian noise)

- ➔ Seismic causes density changes in the ground and shaking of the mirror environment (walls, buildings, vacuum system).
- ➔ These fluctuations cause a change in the gravitational force acting on the mirror.
- ➔ Cannot shield the mirror from gravity. ☹️

Coupling constant (depends on type of seismic waves, soil properties, etc)

Gravitational constant

Density of ground

PSD of strain

$$N_{GG}(f)^2 = \frac{4 \cdot \beta^2 \cdot G^2 \cdot \rho_r^2}{L^2 \cdot f^4} \cdot X_{\text{seis}}^2$$

Arm length

frequency

PSD of seismic

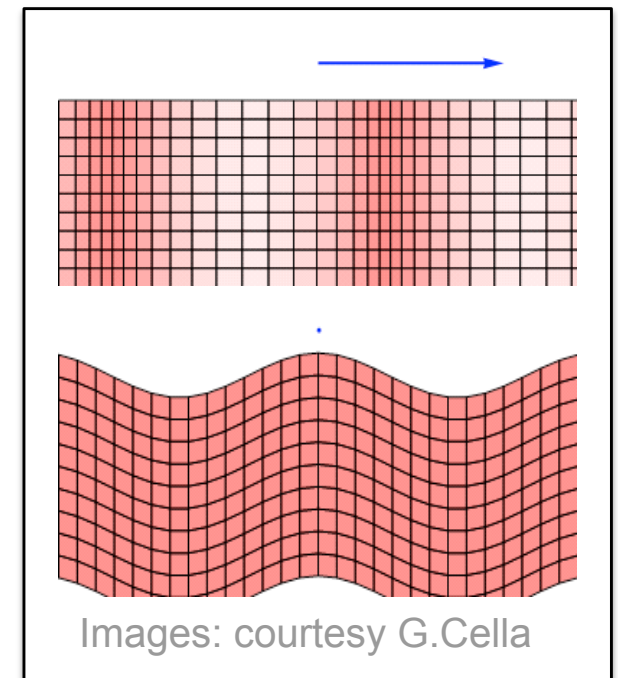



How to reduce Gravity Gradient Noise?

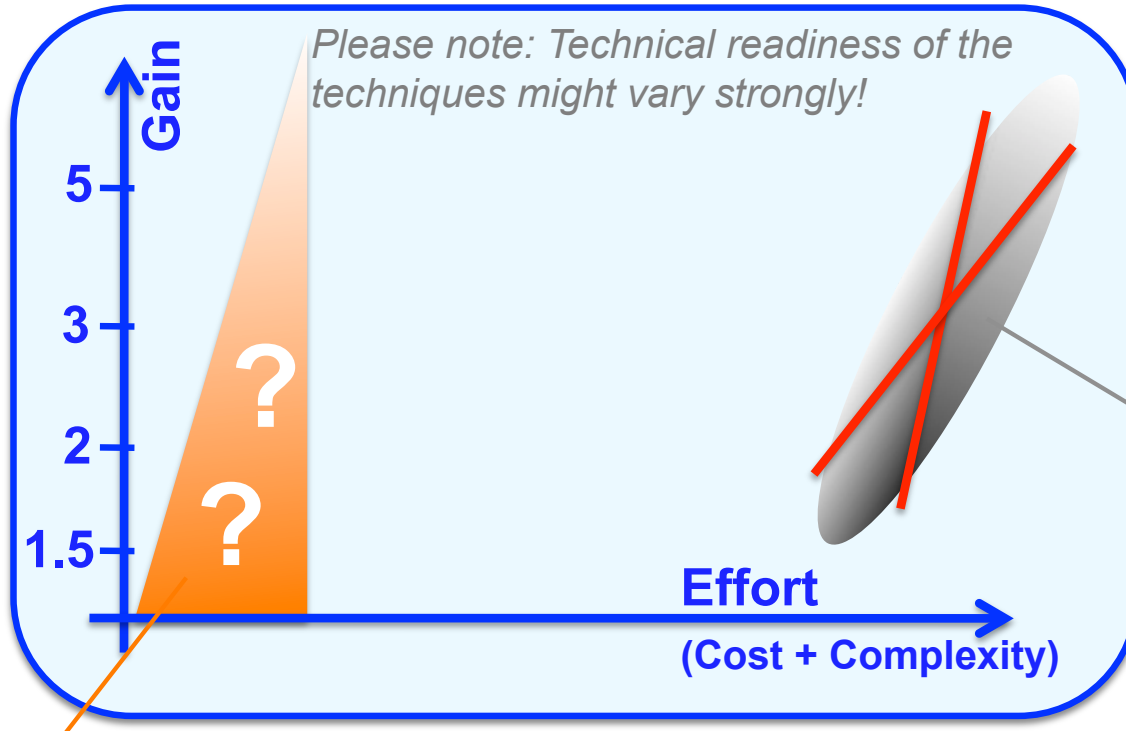

~~Reduce seismic noise at site., i.e. select a quieter site, potentially underground.~~

~~Beker et al, Journal of Physics: Conference Series 363 (2012) 012004~~

Subtraction of gravity gradient noise using an array of seismometers.

- Beker et al: General Relativity and Gravitation Volume 43, Number 2 (2011), 623-656
- Driggers et al: arXiv:1207.0275v1 [gr-qc]

Obviously not possible within the LIGO infrastructure (but consider for other projects, see GW4 session tomorrow)



Quantum Noise

- ➔ Quantum noise is a direct manifestation of the **Heisenberg Uncertainty Principle**.
- ➔ It is comprised of **photon shot noise (sensing noise)** at high frequencies and **photon radiation pressure noise (back-action noise)** at low frequencies.

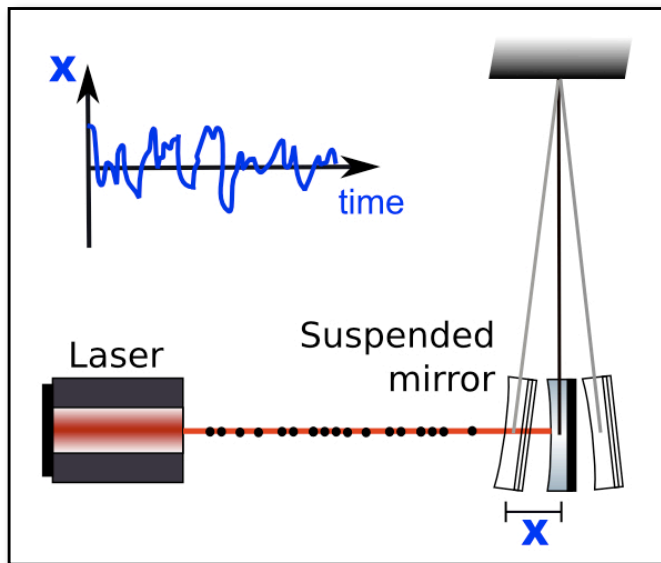

$$h_{\text{sn}}(f) = \frac{1}{L} \sqrt{\frac{\hbar c \lambda}{2\pi P}}$$

Labels: wavelength (pointing to λ), optical power (pointing to P), Arm length (pointing to L).

$$h_{\text{rp}}(f) = \frac{1}{m f^2 L} \sqrt{\frac{\hbar P}{2\pi^3 c \lambda}}$$

Labels: Mirror mass (pointing to m), optical power (pointing to P), Arm length (pointing to L).

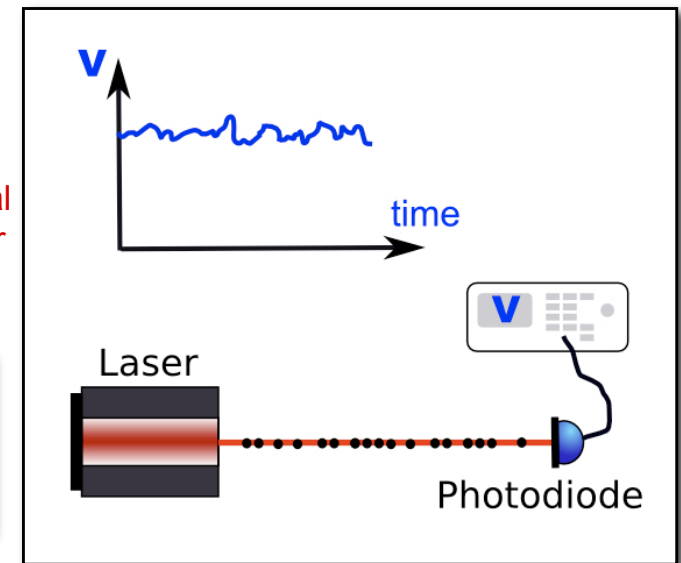

photon radiation pressure noise

photon shot noise



How to reduce Quantum Noise?

Squeezing with frequency dependent squeezing angle

Kimble et al, PRD 65, 2002

Speedmeter

Measures momentum of test masses and is therefore not susceptible to Heisenberg Uncertainty Principle.
Chen, PRD 67, 122004, 2003

Squeezed Light

LIGO Scientific collaboration, Nature Phys. 7 962-65, 2011

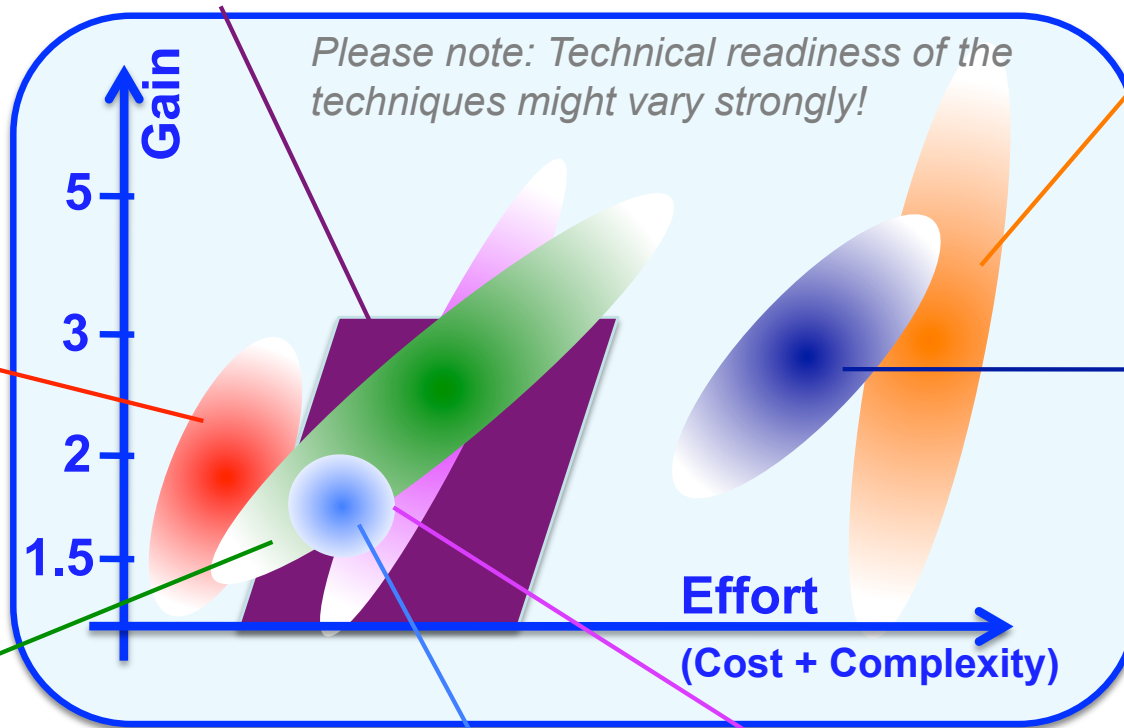

Optical Bar + Optical Lever

Khalili, PLA 298, 308-14, 2002

Increased Laser Power

Need to deal with thermal problems and instabilities

Local readout

Rehbein et al, PRD 78, 062003, 2008

Increased Mirror Weight

Need to deal with thermal problems and instabilities



Contents

- ➔ Background / Introduction
- ➔ A Zoo of technologies to reduce individual noise sources.
 - Suspension thermal noise
 - Gravity gradient noise
 - Mirror thermal noise
 - Quantum noise
- ➔ Example upgrade 1: Team Red design
- ➔ Example upgrade 2: Team Blue design
- ➔ Example upgrade 3: Team Red Xylophone
- ➔ What can we learn from all this?

Suspension Thermal Noise

Assume a boosted aLIGO Quad-suspension:

- ➔ Increased length of last stage to **1.2m** to **reduce suspension thermal noise**.
- ➔ Increased **mirror mass of 160kg** to reduce suspension thermal noise (and radiation pressure noise and coating noise)

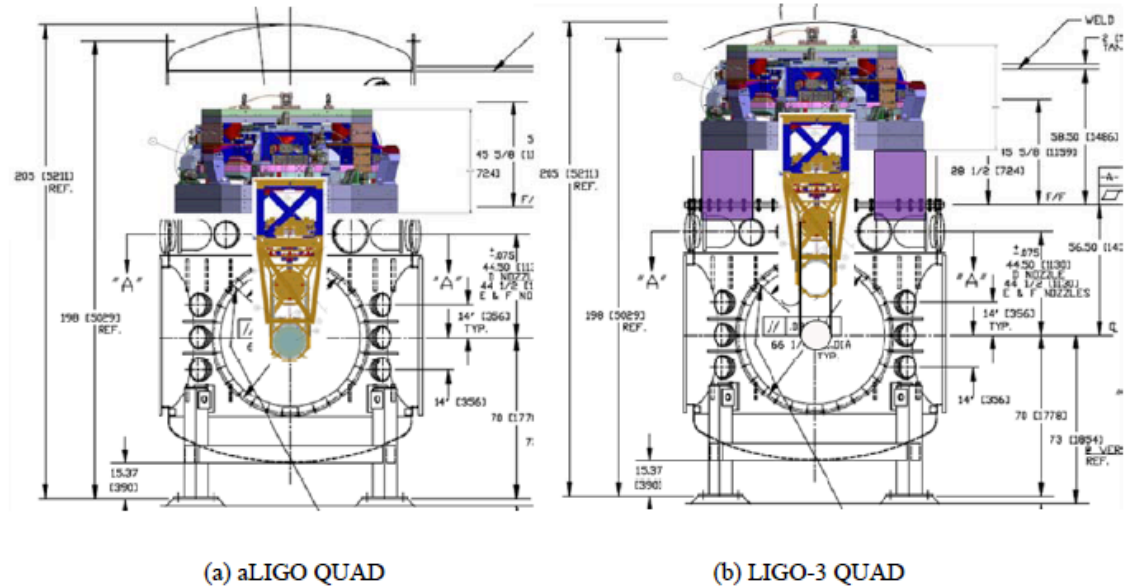

Test Masses and Suspensions		
Mirror Material	Fused Silica	Fused Silica
Main Test Mass Diameter	35 cm	55 cm
Main Test Mass Weight	42 kg	160 kg
Masses in Main Quad (from top)	22 kg/22 kg/40 kg/40 kg	44 kg/66 kg/120 kg/160 kg
Masses in Reaction Chain (from top)	22 kg/22 kg/40 kg/40 kg	22 kg/22 kg/40 kg/40 kg
Total Mass of a Main Suspension	250 kg	520 kg
Length of Final Suspension Stage	0.6 m	1.2 m
Fused Silica Fibre Diameter	400 μm	566 μm
Fibre Diameter at Bending Point	800 μm	1624 μm



Suspension Thermal Noise

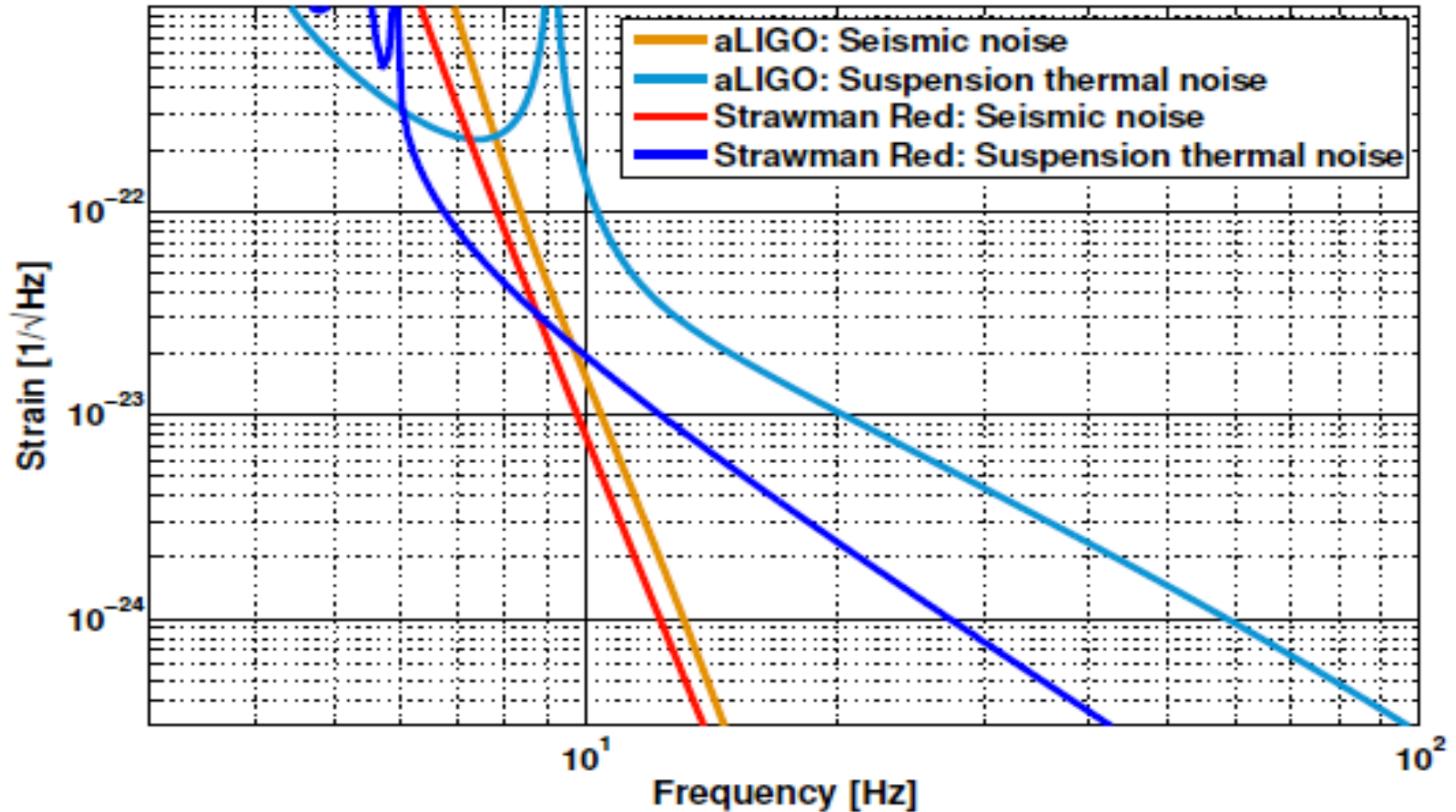



Gravity Gradient Noise

- ➔ **Red design assumes a reduction factor of 5.**
- ➔ Please note seismic noise is not constant. The factor 5 assumed guarantees that 90% of the time the Newtonian noise would be below the LIGO-3 red sensitivity.

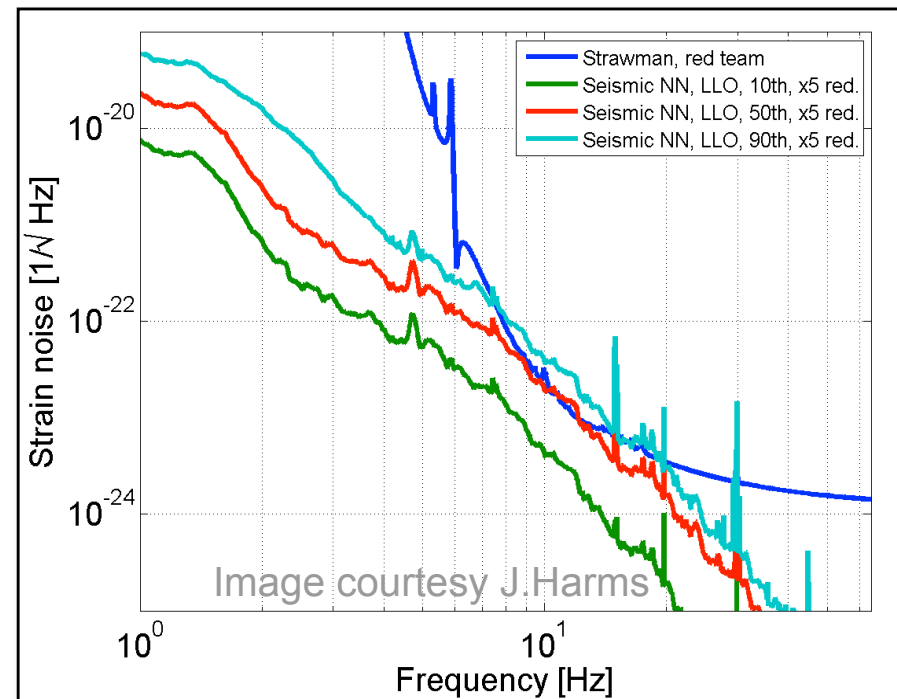
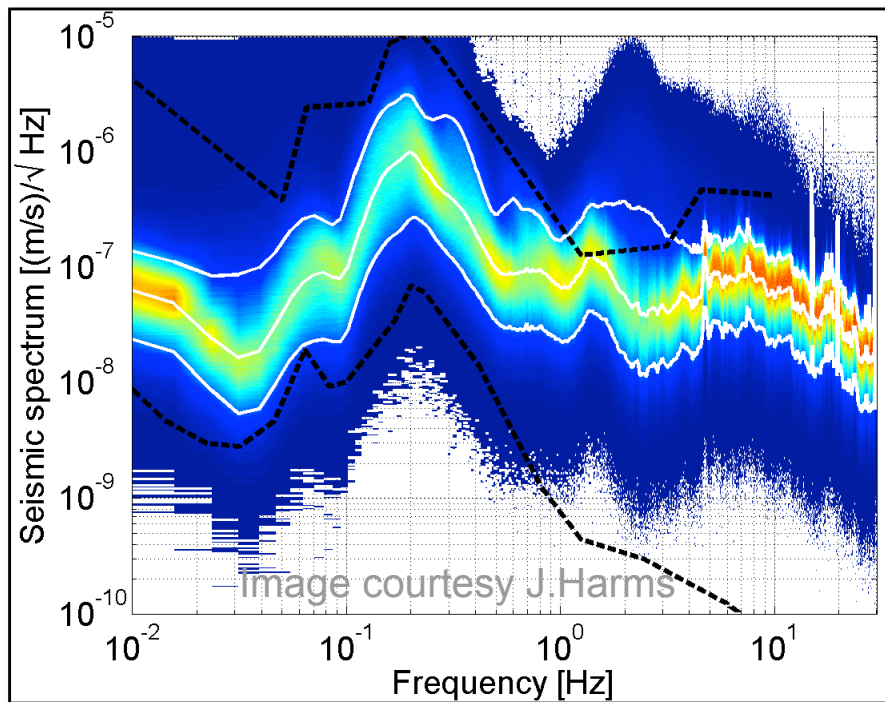



Coating Brownian noise

- ➔ Assumed an overall improvement by a factor **3.2**.
- ➔ Factor **1.6** from increased beam sizes.
- ➔ Another factor of **2** on top of this from either:
 - Better coatings
 - Khalili cavities
 - Resonant waveguide mirrors



Quantum noise

- ➔ We kept the interferometer configuration and the mirror reflectivities the same as in aLIGO baseline.
- ➔ **Introduced frequency dependent input squeezing.**
- ➔ Key aspects: **achievable squeezing level** & **required length of filter cavity**

Laser and Optical Parameters	<i>aLIGO baseline</i>	<i>LIGO-3 red</i>
Laser Wavelength	1064 nm	1064 nm
Optical Power at Test Masses	730 kW	730 kW
Arm Cavity Finesse	450	450
Signal Recycling	$T = 20\%$, tuned	$T = 20\%$, tuned
Squeezing Factor	n.a.	20 dB
Filtercavity (FC) length	n.a.	300 m
FC Detuning	n.a.	-16.8 Hz
FC Input Mirror Transmittance	n.a.	425 ppm
Squeezing Losses	n.a.	9% + 30 ppm roundtrip in FC



Squeezing losses

Frequency independent losses:

- Generation of squeezing: 3%
- Optical isolation: 3 x 0.8%
- Mode matching to IFO and to OMC: 2 x 1%
- OMC loss and QE of PD: 2 x 0.5%
- Mode matching to filter cavity: 1%

= 9% in total

+

Frequency dependent loss (from filtercavity):

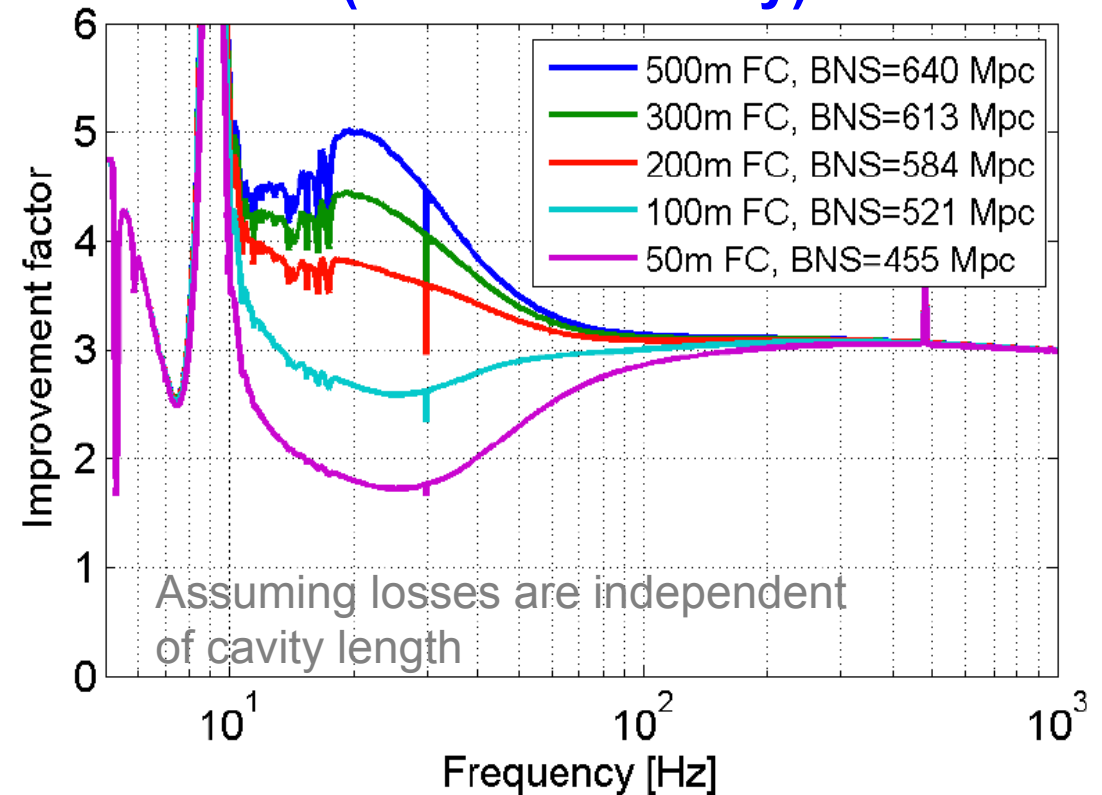

Starting from 20dB squeezing inside the squeezing crystal the losses reduce the observed squeezing to about 9-10dB



Team Red Sensitivity

- ➔ So if we put all the aforementioned things together we get the following sensitivity:
- ➔ Overall an improvement of a factor 3 at all frequencies above 100 Hz. And a factor 3-4 below 100 Hz.
- ➔ The binary neutron star inspiral range would improve from about 200 Mpc to above 600 Mpc.

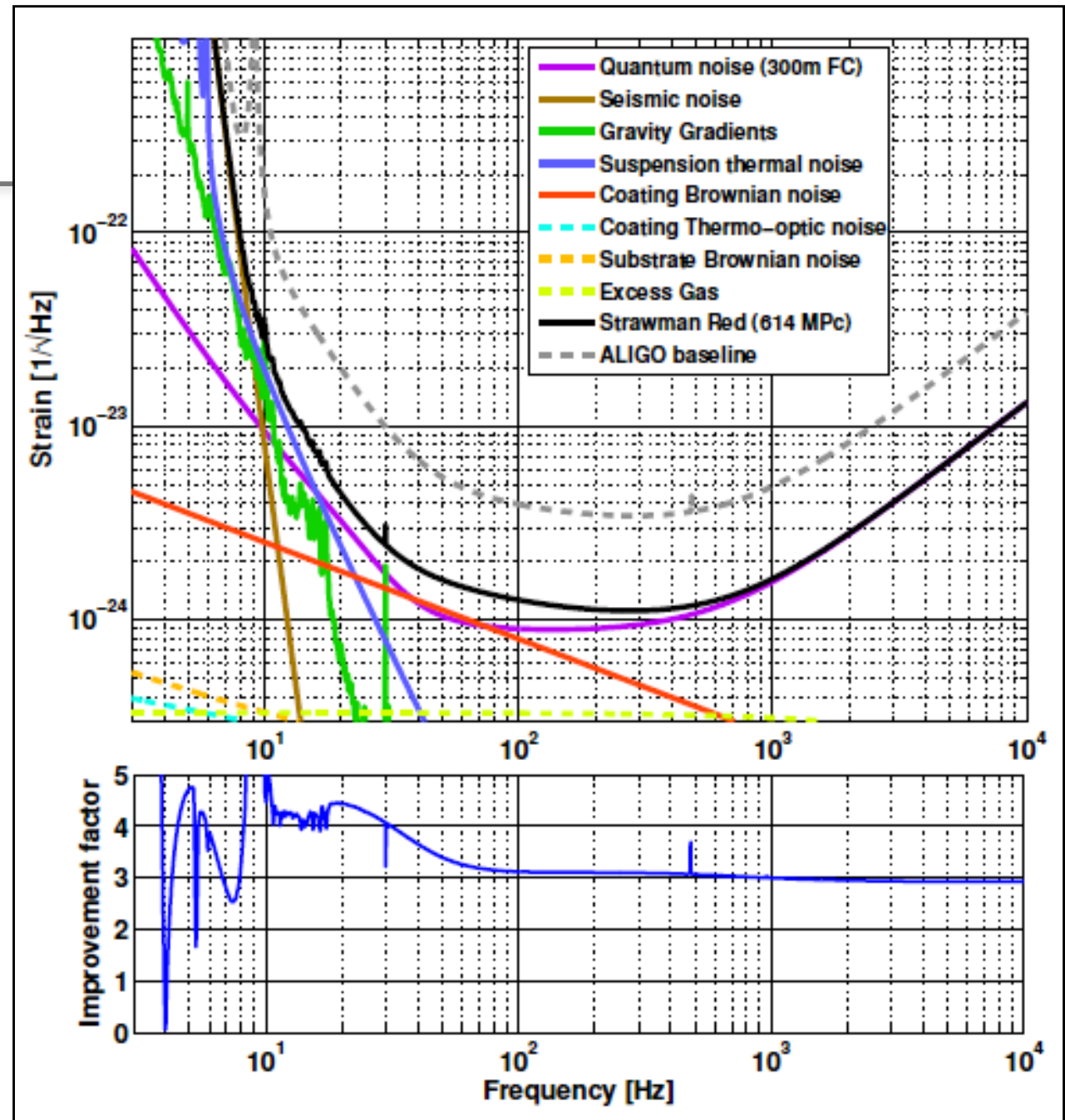



Team Red parameters

- ➔ Rough cost estimate (only hardware included) is about **20 million \$ per interferometer**.
- ➔ Description of the Team Red Design can be found at <https://dcc.ligo.org/cgi-bin/private/DocDB/ShowDocument?docid=78100> or [docid=86550](https://dcc.ligo.org/cgi-bin/private/DocDB/ShowDocument?docid=86550)
- ➔ The sensitivity data for the Team Red design are available at <https://dcc.ligo.org/cgi-bin/private/DocDB/ShowDocument?docid=86562>

Strawman Red Design Overview		
Subsystem and Parameters	Advanced LIGO Baseline Design	Strawman Red Design
Sensitivity		
Binary Neutron Star Inspiral Range	200 Mpc	614 Mpc
Anticipated Strain Sensitivity	$3.5 \cdot 10^{-24} / \sqrt{\text{Hz}}$ @ 300 Hz	$1.2 \cdot 10^{-24} / \sqrt{\text{Hz}}$ @ 250 Hz
Instrument Topology		
Interferometer	Dual-recycled Michelson with Armcavities	Dual-recycled Michelson with Armcavities
Quantum Noise Reduction	n.a	Frequency-dependent input squeezing
Laser and Optical Parameters		
Laser Wavelength	1064 nm	1064 nm
Optical Power at Test Masses	730 kW	730 kW
Arm Cavity Finesse	450	450
Signal Recycling	$T = 20\%$, tuned	$T = 20\%$, tuned
Squeezing Factor	n.a.	20 dB
Filtercavity (FC) length	n.a.	300 m
FC Detuning	n.a.	-16.8 Hz
FC Input Mirror Transmittance	n.a.	425 ppm
Squeezing Losses	n.a.	9% + 30 ppm roundtrip in FC
Test Masses and Suspensions		
Mirror Material	Fused Silica	Fused Silica
Main Test Mass Diameter	35 cm	55 cm
Main Test Mass Weight	42 kg	160 kg
Masses in Main Quad (from top)	22 kg/22 kg/40 kg/40 kg	44 kg/66 kg/120 kg/160 kg
Masses in Reaction Chain (from top)	22 kg/22 kg/40 kg/40 kg	22 kg/22 kg/40 kg/40 kg
Total Mass of a Main Suspension	250 kg	520 kg
Length of Final Suspension Stage	0.6 m	1.2 m
Fused Silica Fibre Diameter	400 μm	566 μm
Fibre Diameter at Bending Point	800 μm	1624 μm
Coating Noise Reduction		
Improvement Factors	n.a.	factor 1.6 from increased beam size PLUS factor 2 from either (i) better coatings, OR (ii) Khalili cavities, OR (iii) waveguides
Operation Temperature	290 K	290 K
IM/EM ROC	1934/2245 m	1849/2173 m
IM/EM spotsize	5.31/6.21 cm	8.46/9.95 cm
Khalili cavity length	n.a.	50 m
Gravity Gradient Noise		
Assumed Seismic Level	???	LLO ETMX, 90th percentile
Assumed subtraction factor	n.a.	5



Contents

- ➔ Background / Introduction
- ➔ A Zoo of technologies to reduce individual noise sources.
 - Suspension thermal noise
 - Gravity gradient noise
 - Mirror thermal noise
 - Quantum noise
- ➔ Example upgrade 1: Team Red design
- ➔ Example upgrade 2: Team Blue design
- ➔ Example upgrade 3: Team Red Xylophone
- ➔ What can we learn from all this?



Blue Design (1)

- ➔ Blue design is much more radical than red design.
- ➔ Based on **cryogenic (120K) silicon test masses** and suspensions to reduce thermal noise.
- ➔ Good properties of silicon:
 - Thermal expansion has a zero-crossing at 120K.
 - High thermal conductivity => smaller thermal gradients.
- ➔ Plan to use 4 times higher optical power than aLIGO.

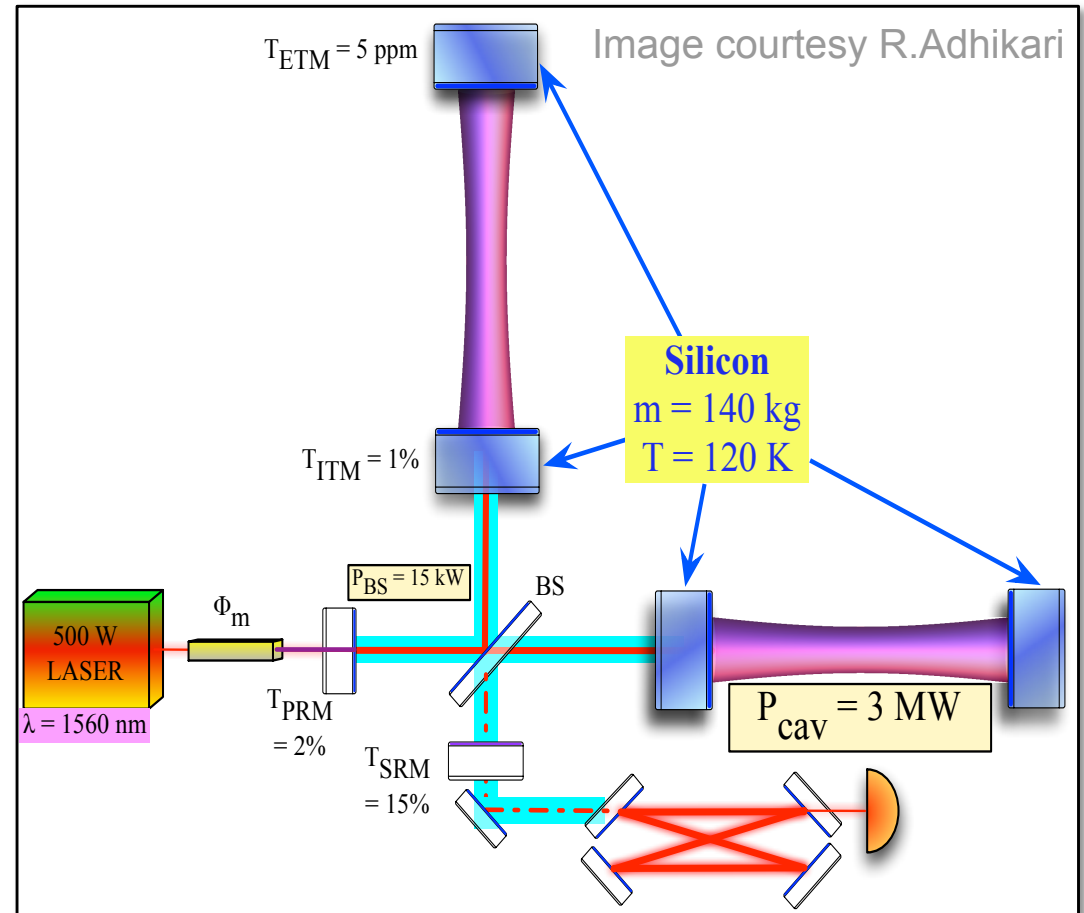

Blue Design (2)

- ➔ In contrast to the Einstein Telescope and KAGRA (both operating at 10-40K range) the **cooling in the blue design will mainly be done via radiation** (and not via conduction through the fibres).
- ➔ As a result the **cryogenic implementation is simpler** and **higher optical powers** can be possible.
- ➔ Lots of R&D required.
- ➔ Blue design **not incremental**.

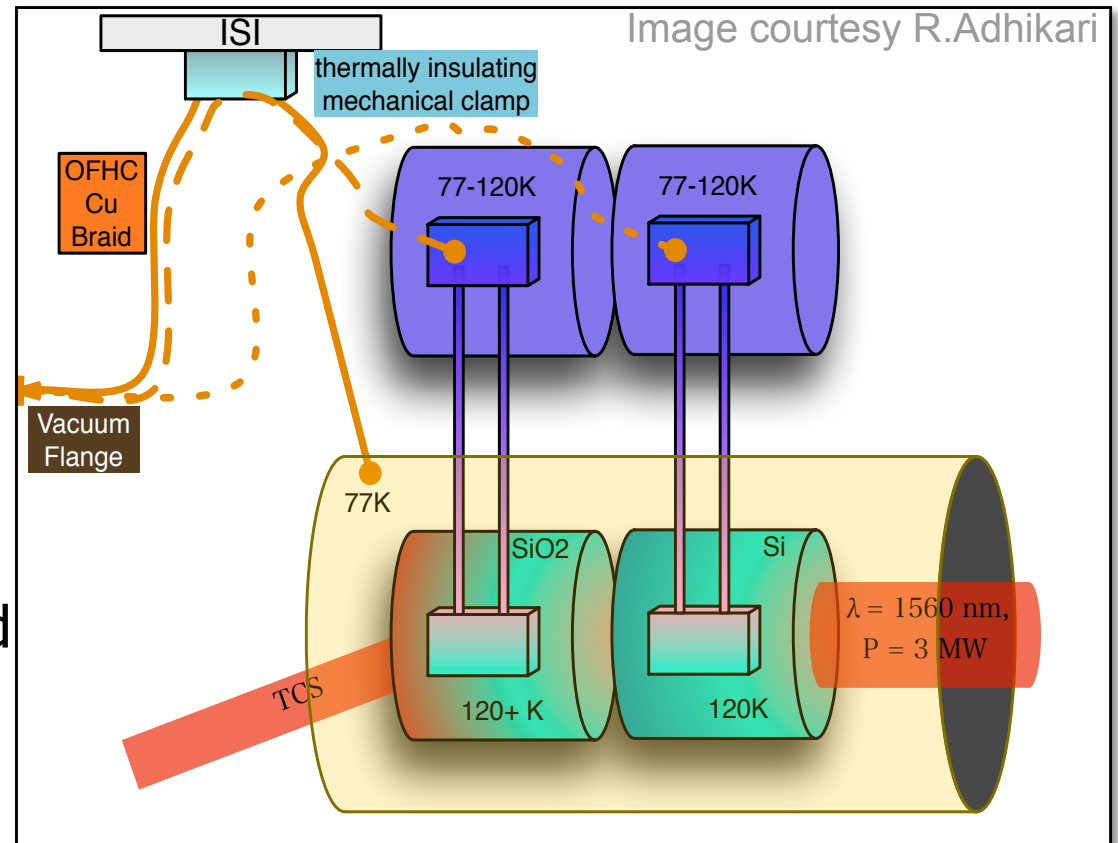



How do red, blue and green designs compare in sensitivity?

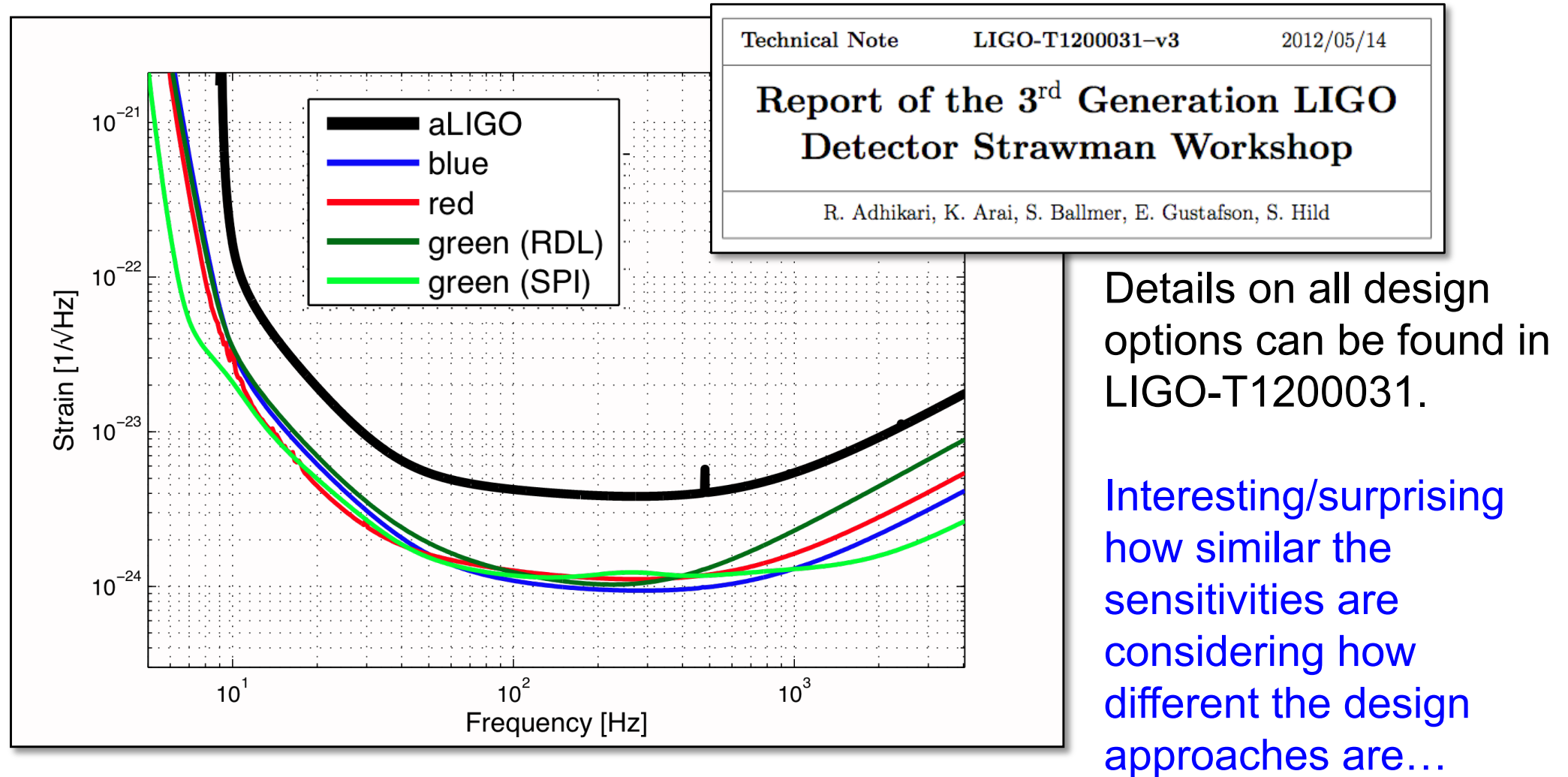



Contents

- ➔ Background / Introduction
- ➔ A Zoo of technologies to reduce individual noise sources.
 - Suspension thermal noise
 - Gravity gradient noise
 - Mirror thermal noise
 - Quantum noise
- ➔ Example upgrade 1: Team Red design
- ➔ Example upgrade 2: Team Blue design
- ➔ Example upgrade 3: Team Red Xylophone
- ➔ What can we learn from all this?



The cooler the better the noise!

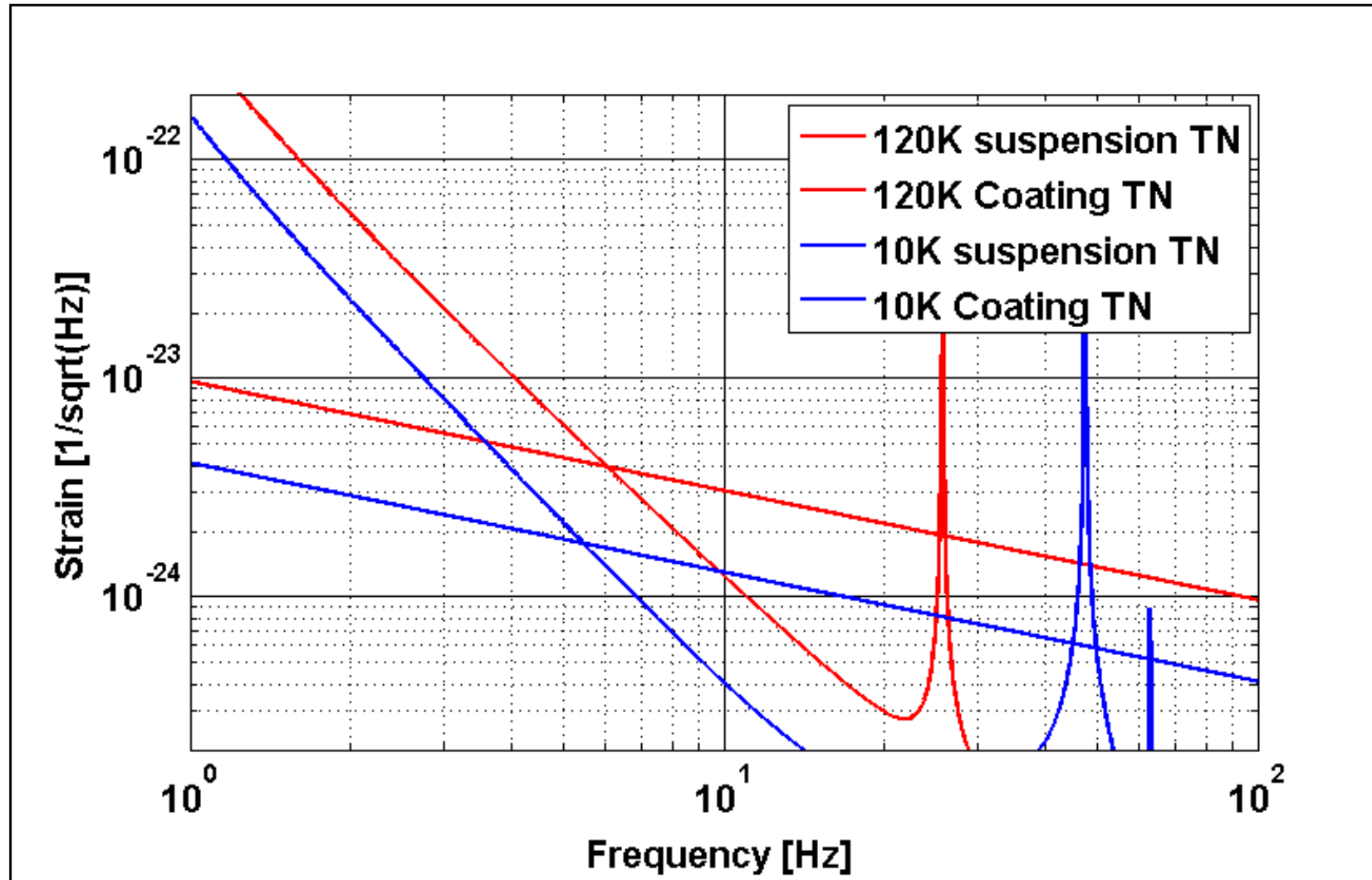

Assumes 160kg silicon test masses. Minimal fibre diameter / ribbon thickness is given by the required heat extraction for the 10K scenario and by the tensile strength for the 120K case.



Xylophone concept

- ➔ Xylophone approach: **Cover the full desired frequency range by building two different interferometers, one covering the low frequency range and one covering the high frequency range.**
- ➔ Resolves the problem of noise sources scaling in opposite direction (e.g. **shot noise versus radiation pressure noise**).
- ➔ Resolves problem of **high power** laser beams on **cryogenic** test masses.
- ➔ Please note: It is already quite amazing that our detectors can span a detection band of 2 to 3 decades in frequency.
- ➔ However, it seems likely that at some point we will find it **easier** (in terms of complexity) and **cheaper** (in terms of cost and time) **to build two simpler interferometers** (each optimised for the noise sources relevant in its frequency range) rather than one extremely complex instrument (optimised for 'everything').



Thermal noise of a cryogenic Silicon suspension

- Allows to extract the power similar to ET-D-LF:
 $18\text{kW} * 1\text{ppm} = 18\text{mW}$
- Cryogenic silicon suspension at 40K.
- Improvement of about factor 10 at 10Hz.
- Stress was chosen to be half of the current (quick) lab measurement.
- Temperature was chosen as a compromise of heat extraction and TN performance.

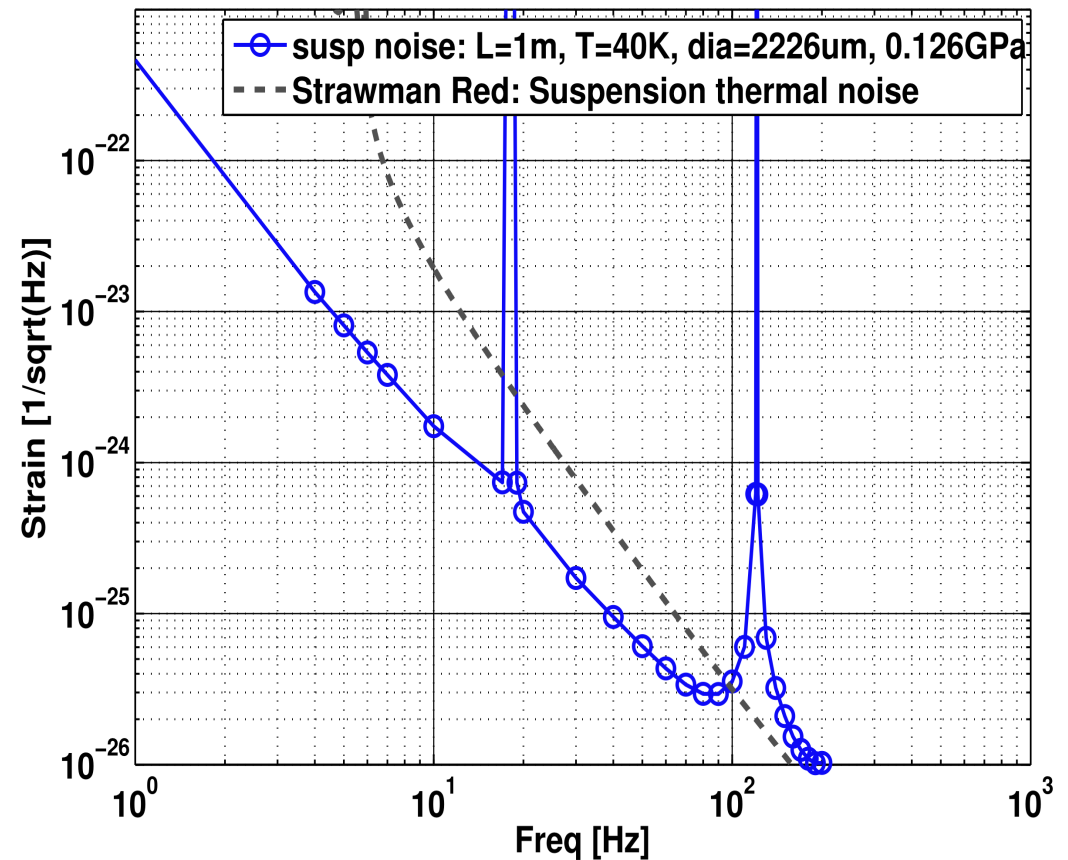



Coating noise of a cryogenic Silicon test mass

- ➔ **Assumes no better than tantala/silica coating on silicon substrate (conservative choice)**
- ➔ Uses measured losses for the coating materials
- ➔ Beam radius of 9 cm.

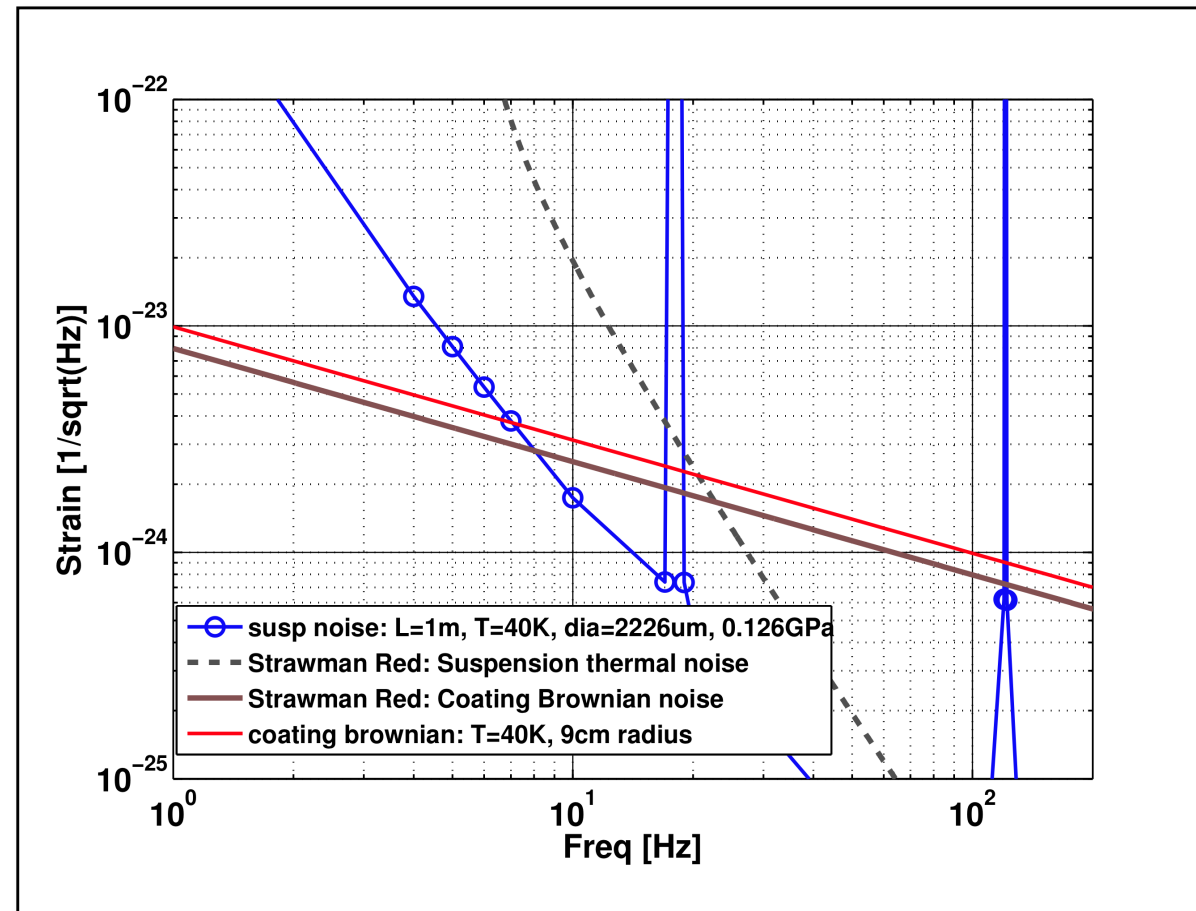



Noise budget of a cryogenic low-frequency detector

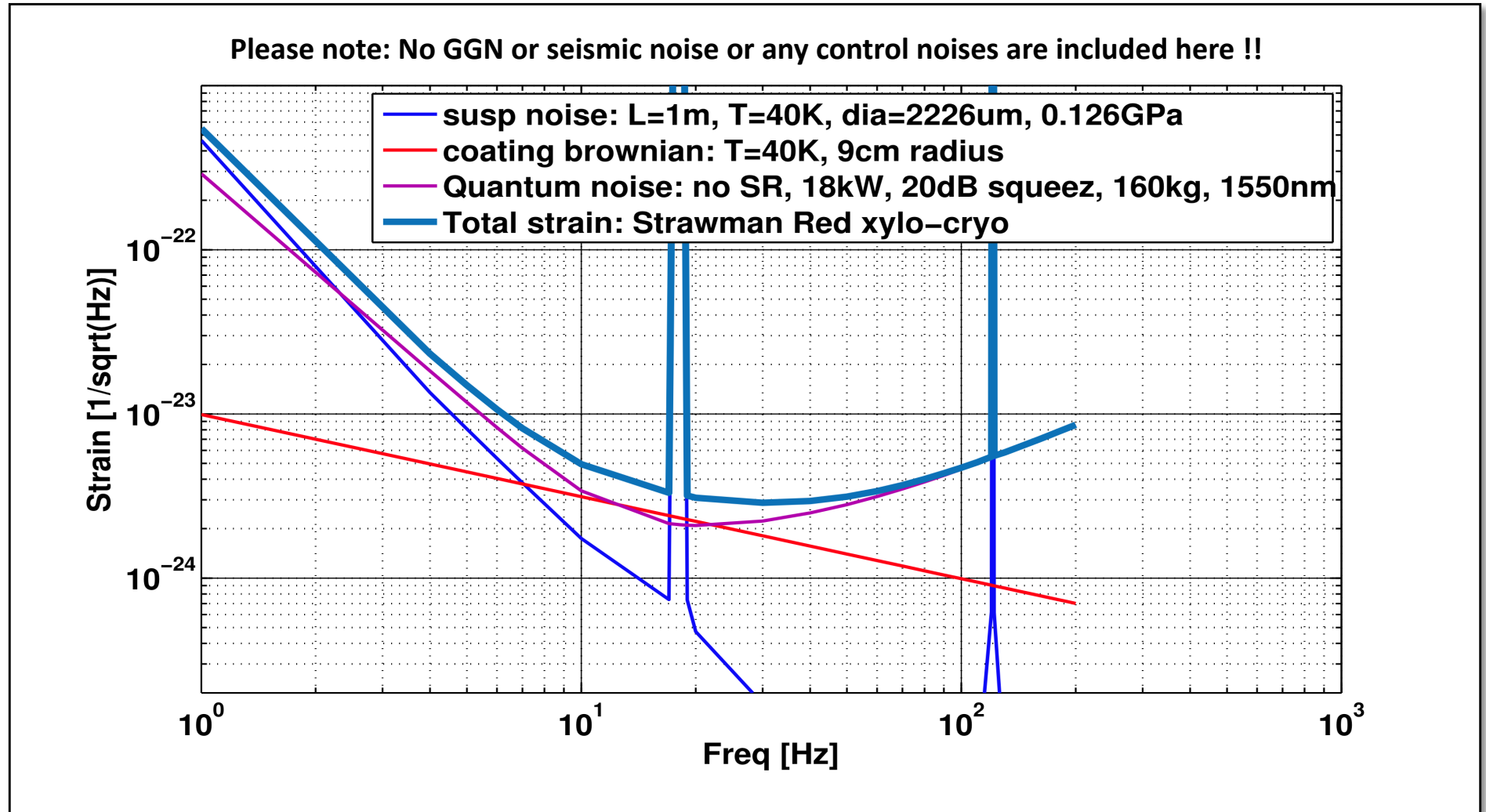



The full xylophone

Please note: No GGN or seismic noise or any control noises are included in the LF detector noise budget !!

Potential improvement

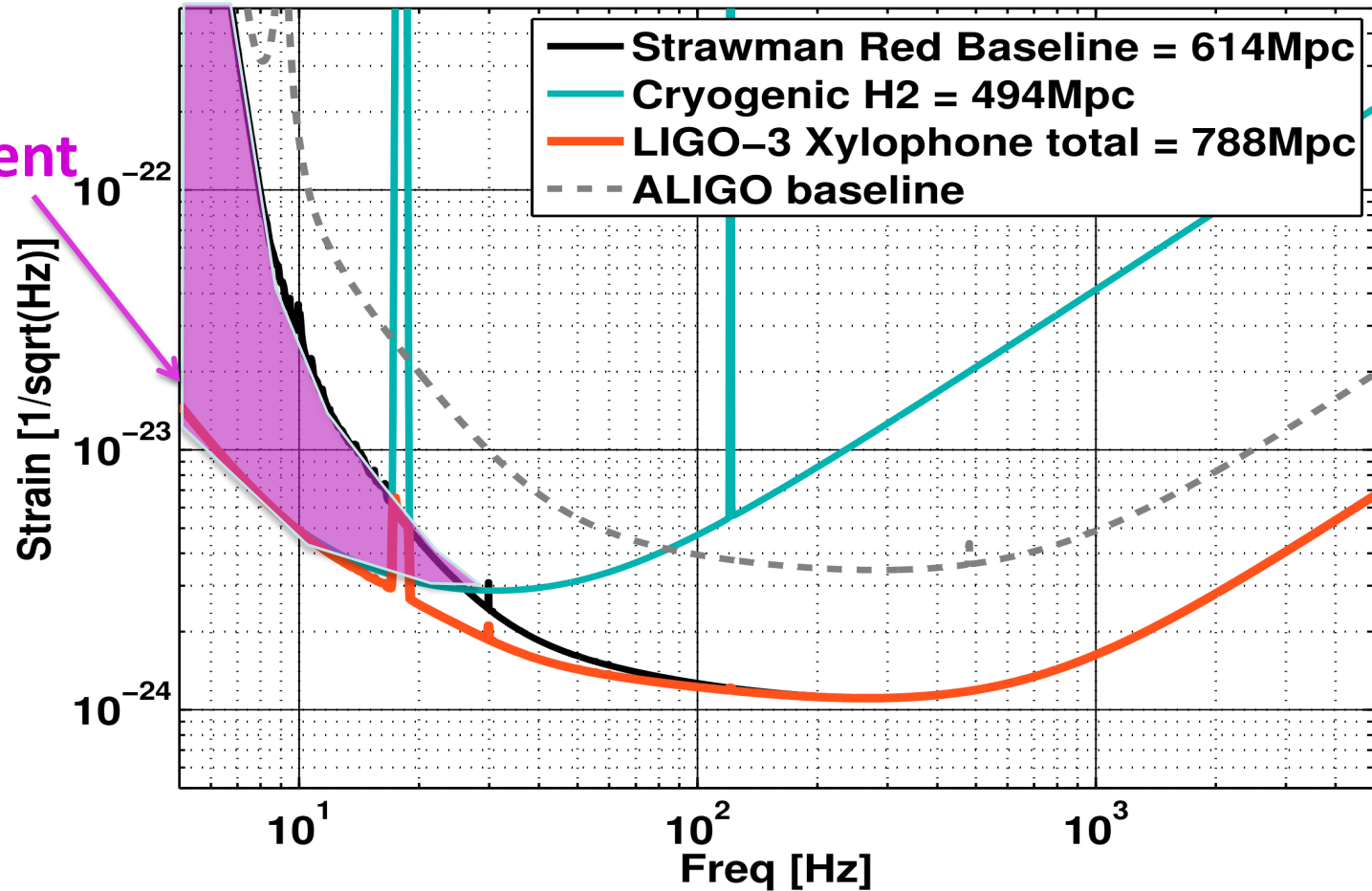

Numbers given in the legend refer to binary neutron star inspiral range.
A lower cut-off frequency of 5Hz was chosen.



Xylophone discussion

- If gravity gradient noise and seismic noise can be mitigated, a **cryogenic** instrument accompanying a RT partner could make a **significant low frequency sensitivity improvement**
- Using a xylophone can allow **simplifying the accompanying room temperature upgrade** (for instance shorter suspensions, lower weight of test masses, shorter filter cavity etc)
- Going for a full xylophone can give **all the benefits of a cryogenic, low-power interferometer** to cover the low frequency range while AT THE SAME TIME give the **full benefit of a not too complex and cost efficient high-power interferometer covering the high frequency end**.
- Also gives us the possibility to learn cryogenics and prepare ourselves for the future.



Contents

- ➔ Background / Introduction
- ➔ A Zoo of technologies to reduce individual noise sources.
 - Suspension thermal noise
 - Gravity gradient noise
 - Mirror thermal noise
 - Quantum noise
- ➔ Example upgrade 1: Team Red design
- ➔ Example upgrade 2: Team Blue design
- ➔ Example upgrade 3: Team Red Xylophone
- ➔ What can we learn from all this?



What can we learn from this? (I)

- ➔ **Advanced LIGO is far away from its facility limits.**
- ➔ The Team Red design would allow an **incremental upgrade**, improving the sensitivity broadband by a factor 3-4.
- ➔ 'You can buy sensitivity at a rate of the order of about 10Mpc/\$1million'.

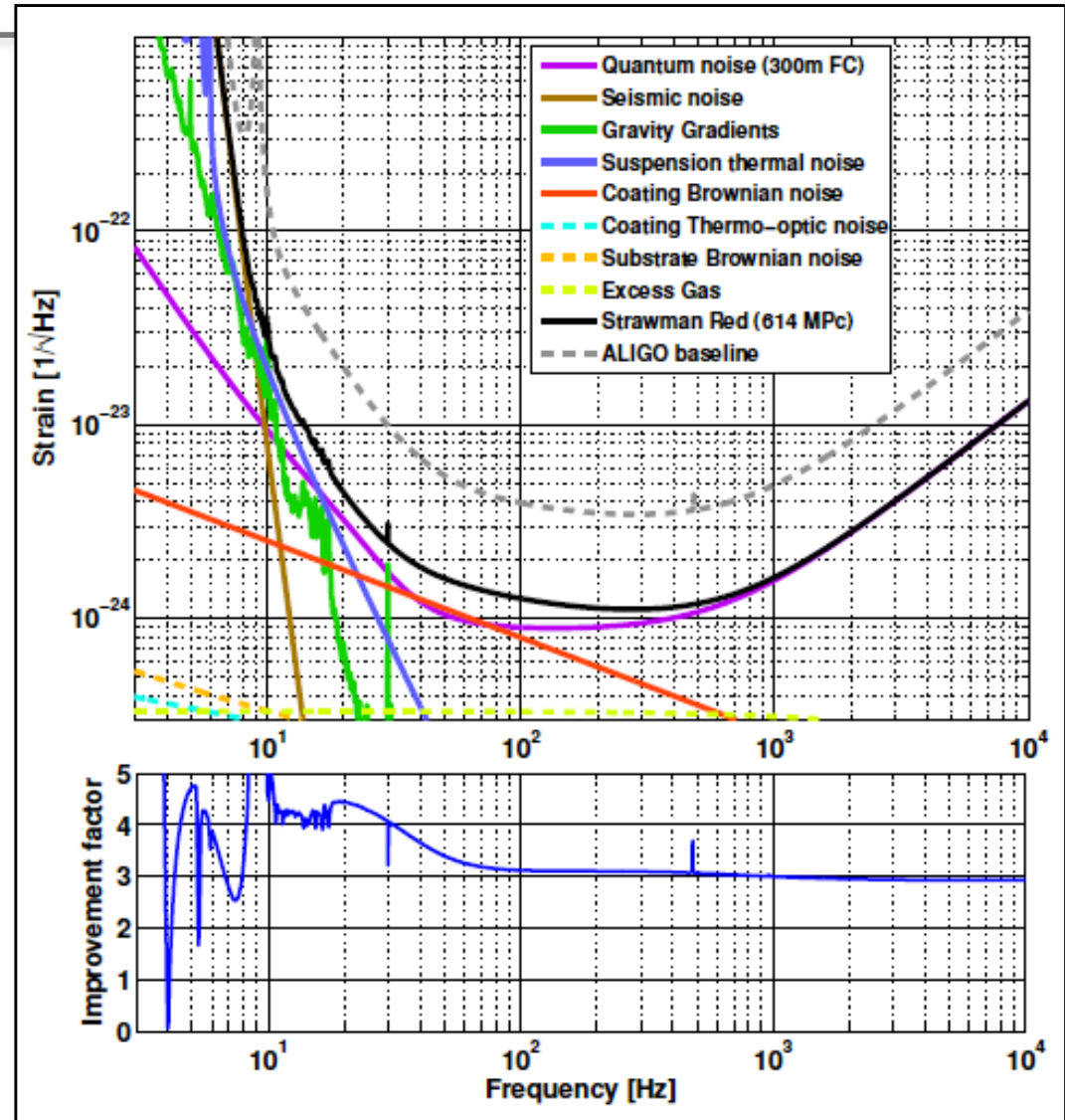



What can we learn from this? (II)

- ➔ **If we are prepared to do without the magic factor of 2 in coating noise improvement, then:**
- ➔ We still get a substantial sensitivity improvement to a BNS range of 430Mpc.
- ➔ But even more importantly: Such a design would only include techniques and know-how that we already have! In principle we could start building such an interferometer right away.

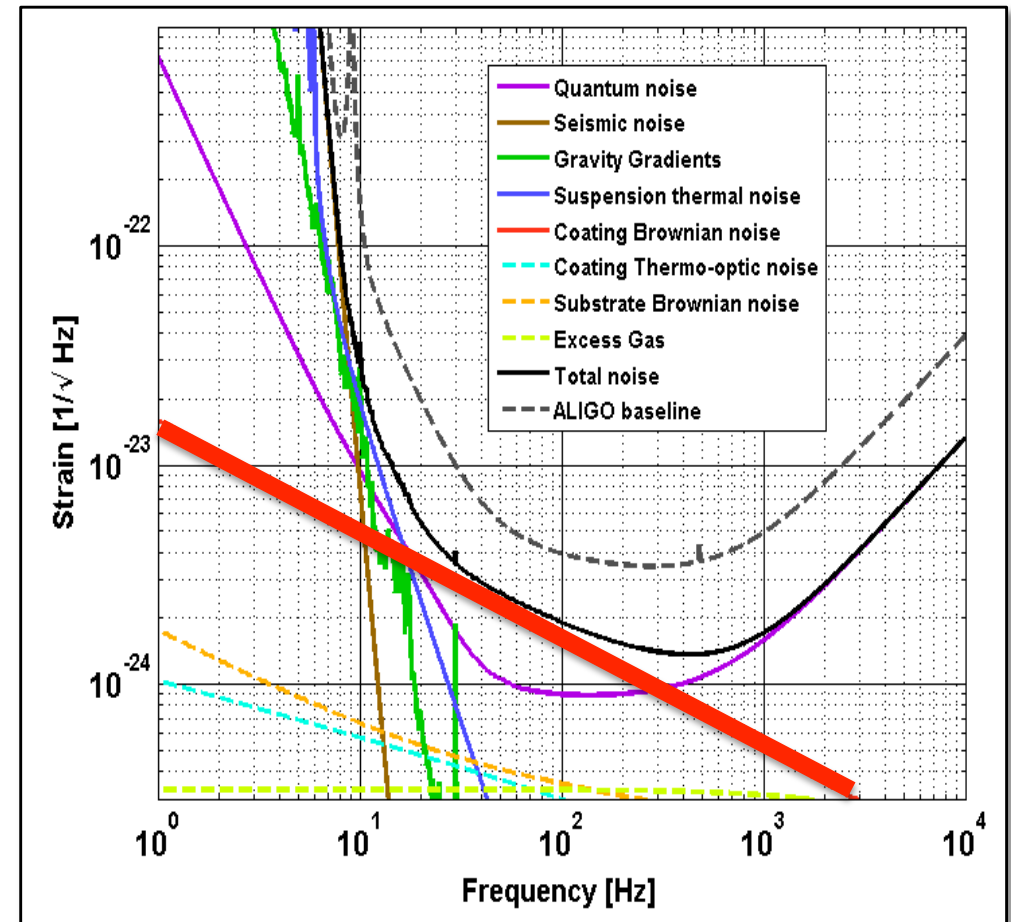



What can we learn from this? (III)

- ➔ The developed designs vary strongly and cover a wide spectrum in terms of **cost**, **technical readiness** of the **involved technologies**, the **required shut-down times** etc.
- ➔ Designs have been extremely useful for **defining what R&D is required** to be carried out over the upcoming years.
- ➔ The LIGO Scientific collaboration intends to further develop the various designs. In a few years, when required timelines and available budget are clearer as well as open R&D questions have been answered, the upgrade plans will be narrowed down to a single design.
- ➔ **Key message for the moment: There will be significant sensitivity improvements possible after Advanced LIGO will have accomplished its mission!**



LIGO-3 sensitivity in context

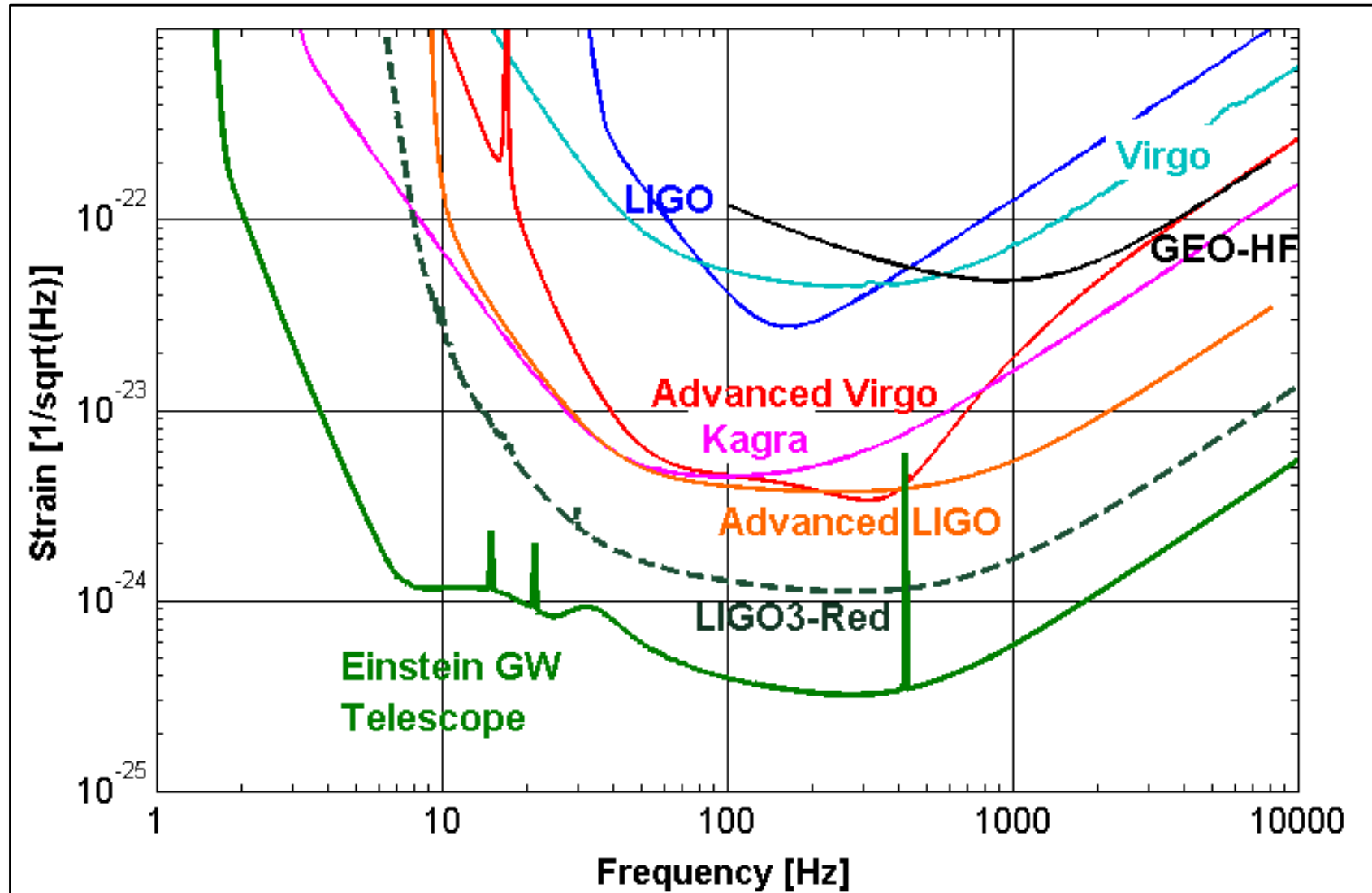



**Thanks very much for your
attention.**